

Major Scales

MAJOR SCALES are the building blocks for all of music. Major scales are built on a specific pattern of half-step and whole-step intervals. The pattern for a major scale is **Whole-step, Whole-step, Half-step, Whole-step, Whole-step, Whole-step, Half-step**. Starting on any note, if you follow this pattern you will build a major scale in the note's key.

Directions: Fill in major scale notes following the interval pattern. Determine the number of sharps or flats. List sharps or flats in order. I have filled in some of the spaces for you.

✓ Check your answers at www.LearnandMasterGuitar.com/answerkey

	<i>Whole</i>	<i>Whole</i>	<i>Half</i>	<i>Whole</i>	<i>Whole</i>	<i>Whole</i>	<i>Half</i>	<i>How many #s or b's?</i>	<i>What are they?</i>
C	<u>D</u>	<u>E</u>	___	___	___	___	___	none	_____

The following scales all contain SHARPS.

G	___	___	___	___	___	<u>F#</u>	___	___	<u>F#</u> , _____
D	___	<u>F#</u>	___	___	___	<u>C#</u>	___	___	<u>F#</u> , <u>C#</u> , _____
A	___	___	___	___	___	___	___	<u>3 #'s</u>	_____
E	___	___	___	___	___	___	___	___	_____
B	___	___	___	___	___	___	___	___	_____
F#	___	___	___	___	___	<u>E#</u>	___	___	_____

The following scales all contain FLATS.

F	___	___	<u>Bb</u>	___	___	___	___	___	_____
Bb	___	___	___	___	___	___	___	___	_____
Eb	___	___	<u>Ab</u>	___	___	___	___	<u>3 b's</u>	_____
Ab	___	___	___	___	___	___	___	___	<u>Bb</u> , <u>Eb</u> , <u>Ab</u> , <u>Db</u>
Db	___	___	___	___	___	___	___	___	_____
Gb	___	___	<u>Cb</u>	___	___	___	___	___	_____

Major Scales Worksheet

Fill in the major scale notes following the whole step half step major scale interval pattern. Determine the number of different sharps and flats for each scale. List the sharps or flats used in each scale in the proper order. Completing this worksheet numerous times helps build the necessary memory recognition of these major scales.

✓ Check your answers with the Answer Key on page 163.

	<i>Whole</i>	<i>Whole</i>	<i>Half</i>	<i>Whole</i>	<i>Whole</i>	<i>Whole</i>	<i>Half</i>	<i>How many sharps (#) or flats (b)?</i>	<i>What are they?</i>
C	___	___	___	___	___	___	___	_____	_____
The following scales all contain SHARPS.									
G	___	___	___	___	___	___	___	_____	_____
D	___	___	___	___	___	___	___	_____	_____
A	___	___	___	___	___	___	___	_____	_____
E	___	___	___	___	___	___	___	_____	_____
B	___	___	___	___	___	___	___	_____	_____
F#	___	___	___	___	___	___	___	_____	_____
The following scales all contain FLATS.									
F	___	___	___	___	___	___	___	_____	_____
Bb	___	___	___	___	___	___	___	_____	_____
Eb	___	___	___	___	___	___	___	_____	_____
Ab	___	___	___	___	___	___	___	_____	_____
Db	___	___	___	___	___	___	___	_____	_____
Gb	___	___	___	___	___	___	___	_____	_____

Major Scales Mixed Worksheet

The order of the scales is mixed between flat and sharp major scales. Fill in major scale notes following the whole step half step major scale interval pattern. Determine the number of different sharps and flats for each scale. List the sharps or flats used in each scale in the proper order.

✓ Check your answers with the Answer Key on page 164.

	<i>Whole</i>	<i>Whole</i>	<i>Half</i>	<i>Whole</i>	<i>Whole</i>	<i>Whole</i>	<i>Half</i>	<i>How many sharps (#) or flats (b)?</i>	<i>What are they?</i>
C	___	___	___	___	___	___	___	_____	_____
Bb	___	___	___	___	___	___	___	_____	_____
D	___	___	___	___	___	___	___	_____	_____
Ab	___	___	___	___	___	___	___	_____	_____
E	___	___	___	___	___	___	___	_____	_____
Gb	___	___	___	___	___	___	___	_____	_____
F#	___	___	___	___	___	___	___	_____	_____
Db	___	___	___	___	___	___	___	_____	_____
A	___	___	___	___	___	___	___	_____	_____
Eb	___	___	___	___	___	___	___	_____	_____
B	___	___	___	___	___	___	___	_____	_____
F	___	___	___	___	___	___	___	_____	_____
G	___	___	___	___	___	___	___	_____	_____

Major Scale Table

Major Scales are the foundation upon which all of the upcoming theory is going to be built. Just like multiplication tables need to be memorized, major scales and the key signatures that they generate have to be learned and memorized. KEY SIGNATURES are the pattern of sharps or flats that each major scale generates.

Directions: Fill in the major scale notes on the following table. Remember, the naturally occurring half-steps are between E-F and B-C.

✓ Check your answers at
www.LearnandMasterGuitar.com/answerkey

	Whole Step	Whole Step	Half Step	Whole Step	Whole Step	Whole Step	Half Step
C	D						
F		A					
B_b			E_b				
E_b				B_b			
A_b					F		
D_b						C	
G_b							G_b
F_#						E_#	
B					G_#		
E				B			
A			D				
D		F_#					
G	A						

Session 7 Assignment

- Memorize the Notes on the Sixth String. (page 43)
- Memorize the 6th String Barre Chord Forms. (page 44)
- Play through 6th String Barre Chord Exercises. Make sure each chord is sounding clear and that the chords change at the right time. (page 44)
- Play Home on the Range, both notes and chords. Try to use all barre chords. (page 47)
- Play Yellow Rose of Texas, both notes and chords. (page 47)
- Complete the Major Scale and the Major Scale Table Worksheets. (pages 45-46)

The Ultimate Major Scale Mix Up

Fill in the major scale notes on the following table. The order of the scales has been mixed up. Each scale will have one note given in a specific place in the major scale pattern. Given the one starting clue you should be able to fill in the rest of the scale by following the major scale pattern given at the top of the table. Remember, the naturally occurring half steps are between E-F and B-C. Good luck!

✓ Check your answers with the Answer Key on page 166.

	<i>Whole Step</i>	<i>Whole Step</i>	<i>Half Step</i>	<i>Whole Step</i>	<i>Whole Step</i>	<i>Whole Step</i>	<i>Half Step</i>
				F			
		F#					
						E	
B							
						D	
		E					
				Db			
		G#					
						F#	
							Db
	B						
					D#		
			Db				

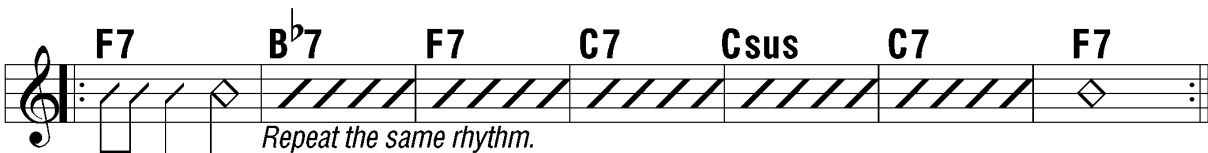
4. 

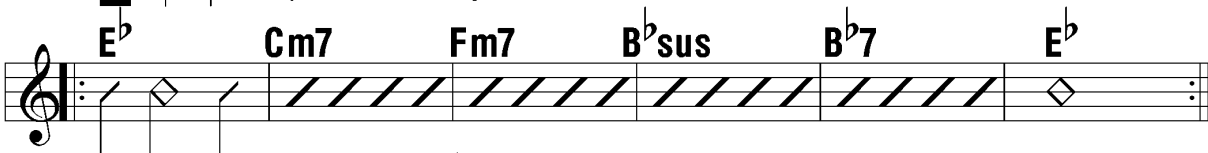
5. 

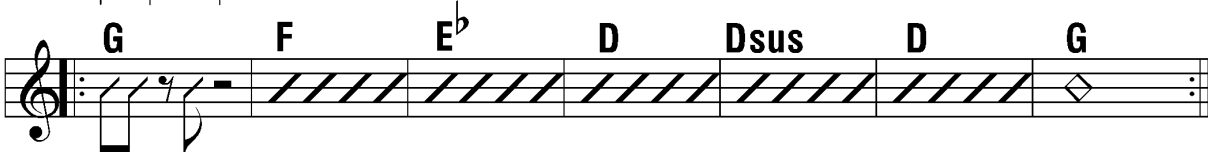
6. 

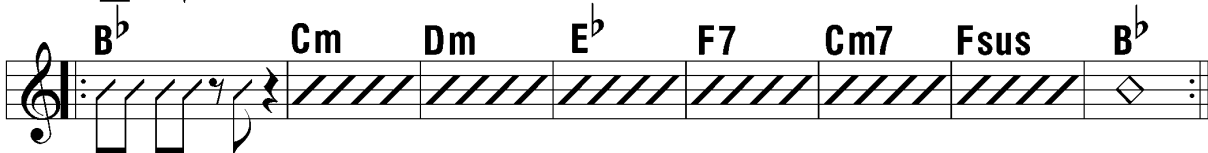
7. 

Keys & Key Signatures

KEY SIGNATURES are derived from the flats or sharps found in a major scale. Each major scale produces a unique combination of sharps or flats as its key signature. A key signature will never have both sharps and flats in it simultaneously. The order of the sharps and flats in a key signature come in a predictable sequence. The key signature order of sharps is F#, C#, G#, D#, A#, E#. The order of flats is Bb, Eb, Ab, Db, Gb, Cb.

Directions: Using your major scales, determine the proper key and list the key signature. Put sharps or flats in the proper order.

✓ Check your answers at www.LearnandMasterGuitar.com/answerkey

- | | |
|--|----------------------|
| 1) What key has 4 flats in its key signature? _____ | What are they? _____ |
| 2) What key has 3 sharps in its key signature? _____ | What are they? _____ |
| 3) What key has 2 flats in its key signature? _____ | What are they? _____ |
| 4) What key has 4 sharps in its key signature? _____ | What are they? _____ |
| 5) In the key of G, what note(s) are sharped/flatted? _____ | |
| 6) In the key of F, what note(s) are sharped/flatted? _____ | |
| 7) In the key of C, what note(s) are sharped/flatted? _____ | |
| 8) In the key of Db, what note(s) are sharped/flatted? _____ | |
| 9) In the key of B, what note(s) are sharped/flatted? _____ | |
| 10) What key has 2 sharps in its key signature? _____ | What are they? _____ |
| 11) What key has 5 sharps in its key signature? _____ | What are they? _____ |

Theory Tips & Tricks...How to determine a key by looking at the key signature.**For Keys with Sharps:** The key is one half-step up from the last sharp in the key signature.*For example, if the key signature is F#, C#, G#, then the last sharp is G#. One half-step up from G# is A. The key is A.***For Keys with Flats:** The key is the next to last flat in the key signature.*For example, if the key signature is Bb, Eb, Ab, the next to last flat is Eb. So, the key is Eb.*

- 12) If the key signature has a Bb and an Eb in it, what's the key? _____
- 13) If the key signature has an F#, C#, G#, and a D#, what's the key? _____
- 14) If the key signature is F# and C#, what's the key? _____
- 15) If the key signature is Bb, Eb, Ab, and Db, what's the key? _____
- 16) If the key signature is F#, C#, G#, D#, A#, and E#, what's the key? _____

Relative Major and Minor Scales

There is a unique relationship between the keys of major scales and minor scales. This relationship is called RELATIVE. **Relative major and minor scales share the same key signatures.** To derive a relative minor scale: Go to the 6th step of the major scale and build an 8 note scale in that key. You can get to the 6th step of any major scale by either going up six steps from the root or down two steps. So, the C major scale and the A minor scale share the same key signature. Therefore A is the relative minor of C major and conversely C is the relative major of A minor.

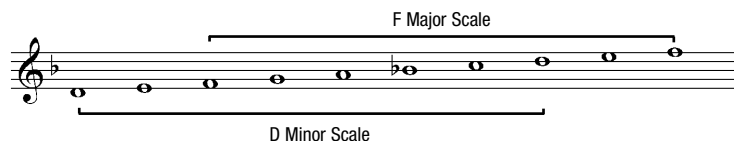
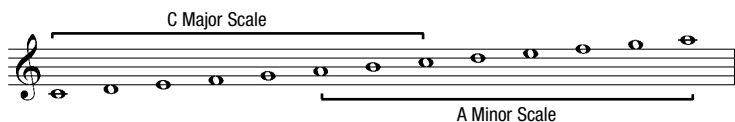
***Session 8 Assignment***

- Memorize the 5th String Barre Chord Forms. (page 48)
- Play through 5th String Barre Chord Exercises. Make sure each chord is sounding clear and that the chords change at the right time. (pages 48-49)
- Play Jamaica Farewell in F, both notes and chords. Use 6th and 5th string barre chords. (page 51)
- Play Jamaica Farewell in G, both notes and chords. Use 6th and 5th string barre chords. (page 51)
- Complete the Keys & Key Signatures Worksheet. (pages 49-50)

Keys & Key Signatures Worksheet

KEY SIGNATURES are derived from the flats or sharps found in a major scale. Each major scale produces a unique combination of sharps or flats as its key signature. A key signature will never have both sharps and flats in it simultaneously. The order of the sharps and flats in a key signature comes in a predictable sequence. The key signature order of sharps is F#, C#, G#, D#, A#, E#. The order of flats is Bb, Eb, Ab, Db, Gb, Cb. Using your major scales, determine the proper key and list the key signature. Put sharps or flats in the proper order.

✓ Check your answers with the Answer Key on page 167.

- 1) What key has 4 sharps in its key signature? _____ What are they? _____
- 2) What key has 3 flats in its key signature? _____ What are they? _____
- 3) What key has 2 sharps in its key signature? _____ What are they? _____
- 4) What key has 4 flats in its key signature? _____ What are they? _____
- 5) In the key of Bb, what note(s) are sharped/flatted? _____
- 6) In the key of G, what note(s) are sharped/flatted? _____
- 7) In the key of C, what note(s) are sharped/flatted? _____
- 8) In the key of E, what note(s) are sharped/flatted? _____
- 9) In the key of Eb, what note(s) are sharped/flatted? _____
- 10) What key has 2 flats in its key signature? _____ What are they? _____
- 11) What key has 5 flats in its key signature? _____ What are they? _____
- 12) What key has 1 sharp in its key signature? _____ What is it? _____
- 13) What key has 3 sharps in its key signature? _____ What are they? _____
- 14) If the key signature has an F# and a C# in it, what's the key? _____
- 15) If the key signature has a Bb, Eb, Ab, and a Db, what's the key? _____
- 16) If the key signature is Bb and Eb, what's the key? _____
- 17) If the key signature is F#, C#, G#, and D#, what's the key? _____
- 18) If the key signature is Bb, Eb, Ab, Db, Gb, and Cb, what's the key? _____

Determining a Key from a Key Signature

There are two simple rules to help you determine a key from the key signature written on a piece of music.

For Keys with Sharps: The key is one half step UP from the last sharp in the key signature.

For example, if the key signature is F#, C#, G#, then the last sharp is G#. One half step up from G# is A. The key is A.











For Keys with Flats: The key is the next to last flat in the key signature.

For example, if the key signature is Bb, Eb, Ab, then the next to last flat is Eb. So, the key is Eb. Remember, if the key signature has only one flat then the key is F.

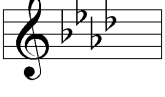
✓ Check your answers with the Answer Key on page 168.

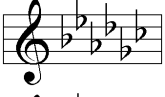
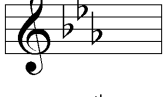
Key Signature

What's the Key?

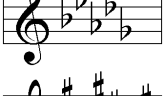
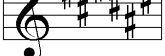
- | | | |
|-----|---|-------|
| 1) |  | _____ |
| 2) |  | _____ |
| 3) |  | _____ |
| 4) |  | _____ |
| 5) |  | _____ |
| 6) |  | _____ |
| 7) |  | _____ |
| 8) |  | _____ |
| 9) |  | _____ |
| 10) |  | _____ |
| 11) |  | _____ |
| 12) |  | _____ |
| 13) |  | _____ |

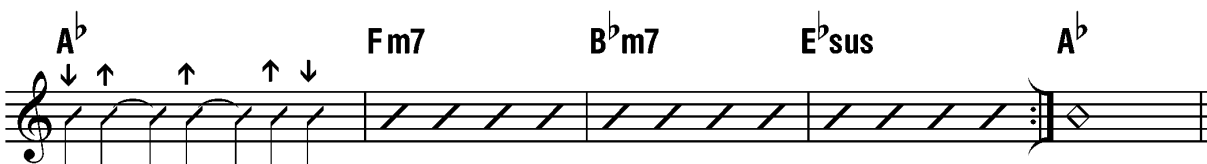
3. 

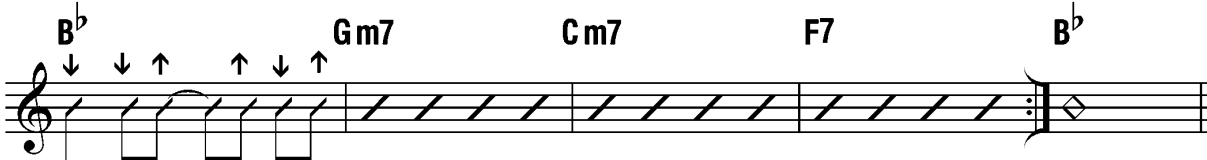
4. 

Diatonic Intervals

INTERVALS are the distance between two notes. DIATONIC refers to intervals that are found within the major scale. You will be given the key and a specific scale step and then you will need to derive the specific note. Here are some examples ...

1) In C, what is the 3rd step? The C scale is C - D - **E** - F - G - A - B - C. The 3rd step is E.

2) In A, what is the 6th? The A scale is A - B - C# - D - E - **F#** - G# - A. The 6th step is F#.

Diatonic Intervals Worksheet

Directions: Fill in the correct note corresponding to the diatonic interval asked for.

✓ Check your answers at www.LearnandMasterGuitar.com/answerkey

- | | | | |
|-----------------------------|-------------------|------------------------------|-------------------|
| 1) In C, what is the 4th ? | <u> F </u> | 11) In G, what is the 5th ? | <u> </u> |
| 2) In F, what is the 6th ? | <u> D </u> | 12) In D, what is the 7th ? | <u> </u> |
| 3) In Ab, what is the 4th ? | <u> </u> | 13) In A, what is the 3rd ? | <u> </u> |
| 4) The 4th in D is | <u> </u> | 14) The 6th in Gb is | <u> </u> |
| 5) The 6th in E is | <u> </u> | 15) The 7th in Db is | <u> </u> |
| 6) In D, what is the 6th ? | <u> </u> | 16) In Bb, what is the 6th ? | <u> </u> |
| 7) In G, what is the 7th ? | <u> </u> | 17) In F, what is the 7th ? | <u> </u> |
| 8) In Db, what is the 2nd ? | <u> </u> | 18) The 2nd in B is | <u> </u> |
| 9) The 2nd in F# is | <u> </u> | 19) The 3rd in F# is | <u> </u> |
| 10) The 3rd in D is | <u> </u> | 20) The 3rd in Gb is | <u> </u> |

Harmonic Intervals Worksheet

Directions: Fill in the correct note corresponding to the harmonic interval asked for. Add double sharps or flats if needed.

✓ Check your answers at www.LearnandMasterGuitar.com/answerkey

- | | |
|--|------------------------------------|
| 1) In C, what is the minor 6th ? <u>Ab</u> | 6) The minor 2nd in D is _____ |
| 2) In F, what is the augmented 2nd ? <u>G#</u> | 7) The augmented 6th in E is _____ |
| 3) In Bb, what is the diminished 5th ? _____ | 8) The minor 7th in B is _____ |
| 4) In Eb, what is the minor 3rd ? _____ | 9) The minor 6th of F# is _____ |
| 5) In Ab, what is the diminished 5th ? _____ | 10) The minor 7th of G is _____ |

Session 9 Assignment

- Practice all of the Strumming Examples given. Start slowly, then gradually increase your speed. Remember to use good technique and to always keep your strumming hand going. (pages 52-53)
- Play La Bamba, both notes and chords, using the strumming pattern given. (page 55)
- Play The Wabash Cannonball, both notes and chords, with the strumming pattern. (page 56)
- Play Blues in E, both notes and chords, with the strumming pattern. (page 56)
- Complete the Interval Worksheets. (pages 53, 55)

 **Jam Along CD #3**
Track 2 - Slow Version
Track 3 - Medium Version
Track 4 - Fast Version

La Bamba

A ↓ D ↓ E ↓ ↑ ↑ ↑ ↓ ↓ ↓ ↑ ↑ ↓ ↓



Strumming Pattern



Diatonic Intervals Worksheet

INTERVALS are the distance between two notes. DIATONIC refers to intervals found within the major scale. Use your knowledge of major scales and key signatures to fill in the correct note corresponding to the diatonic interval. Only scales that have a key signature up to three accidentals are used. These would be the C, F, G, Bb, D, Eb, & A scales.

✓ Check your answers with the Answer Key on page 169.

- | | | | |
|--|---------------|--|---------------|
| 1) In C, what is the 3 rd ? | <u> E </u> | 21) In A, what is the 7 th ? | <u> </u> |
| 2) In F, what is the 5 th ? | <u> C </u> | 22) In C, what is the 5 th ? | <u> </u> |
| 3) In G, what is the 2 nd ? | <u> </u> | 23) In F, what is the 4 th ? | <u> </u> |
| 4) In Bb, what is the 4 th ? | <u> </u> | 24) In G, what is the 5 th ? | <u> </u> |
| 5) In D, what is the 3 rd ? | <u> </u> | 25) In Bb, what is the 7 th ? | <u> </u> |
| 6) The 7 th in Eb is | <u> </u> | 26) The 2 nd in D is | <u> </u> |
| 7) The 2 nd in A is | <u> </u> | 27) The 2 nd in Eb is | <u> </u> |
| 8) The 6 th in C is | <u> </u> | 28) The 3 rd in A is | <u> </u> |
| 9) The 7 th in F is | <u> </u> | 29) The 7 th in C is | <u> </u> |
| 10) The 3 rd in G is | <u> </u> | 30) The 2 nd in F is | <u> </u> |
| 11) In Bb, what is the 6 th ? | <u> </u> | 31) In G, what is the 7 th ? | <u> </u> |
| 12) In D, what is the 5 th ? | <u> </u> | 32) In Bb, what is the 5 th ? | <u> </u> |
| 13) In Eb, what is the 3 rd ? | <u> </u> | 33) In D, what is the 6 th ? | <u> </u> |
| 14) In A, what is the 4 th ? | <u> </u> | 34) In Eb, what is the 4 th ? | <u> </u> |
| 15) In C, what is the 2 nd ? | <u> </u> | 35) In A, what is the 5 th ? | <u> </u> |
| 16) The 3 rd in F is | <u> </u> | 36) The 4 th in C is | <u> </u> |
| 17) The 6 th in G is | <u> </u> | 37) The 6 th in F is | <u> </u> |
| 18) The 3 rd in Bb is | <u> </u> | 38) The 4 th in G is | <u> </u> |
| 19) The 7 th in D is | <u> </u> | 39) The 2 nd in Bb is | <u> </u> |
| 20) The 5 th in Eb is | <u> </u> | 40) The 4 th in D is | <u> </u> |

Diatonic Intervals by Key Worksheet

Using your knowledge of major scales and key signatures fill in the correct note corresponding to the diatonic interval asked for. The exercises are grouped into keys.

✓ Check your answers with the Answer Key on page 170.

<p>In the Key of C...</p> <p>1) What is the 3rd ? _____</p> <p>2) What is the 5th ? _____</p> <p>3) What is the 7th ? _____</p> <p>4) What is the 2nd ? _____</p> <p>5) What is the 4th ? _____</p> <p>6) What is the 6th ? _____</p>	<p>In the Key of F...</p> <p>1) What is the 3rd ? _____</p> <p>2) What is the 5th ? _____</p> <p>3) What is the 7th ? _____</p> <p>4) What is the 2nd ? _____</p> <p>5) What is the 4th ? _____</p> <p>6) What is the 6th ? _____</p>	<p>In the Key of Bb...</p> <p>1) What is the 3rd ? _____</p> <p>2) What is the 5th ? _____</p> <p>3) What is the 7th ? _____</p> <p>4) What is the 2nd ? _____</p> <p>5) What is the 4th ? _____</p> <p>6) What is the 6th ? _____</p>
<p>In the Key of Eb...</p> <p>1) What is the 3rd ? _____</p> <p>2) What is the 5th ? _____</p> <p>3) What is the 7th ? _____</p> <p>4) What is the 2nd ? _____</p> <p>5) What is the 4th ? _____</p> <p>6) What is the 6th ? _____</p>	<p>In the Key of Ab...</p> <p>1) What is the 3rd ? _____</p> <p>2) What is the 5th ? _____</p> <p>3) What is the 7th ? _____</p> <p>4) What is the 2nd ? _____</p> <p>5) What is the 4th ? _____</p> <p>6) What is the 6th ? _____</p>	<p>In the Key of Db...</p> <p>1) What is the 3rd ? _____</p> <p>2) What is the 5th ? _____</p> <p>3) What is the 7th ? _____</p> <p>4) What is the 2nd ? _____</p> <p>5) What is the 4th ? _____</p> <p>6) What is the 6th ? _____</p>
<p>In the Key of Gb...</p> <p>1) What is the 3rd ? _____</p> <p>2) What is the 5th ? _____</p> <p>3) What is the 7th ? _____</p> <p>4) What is the 2nd ? _____</p> <p>5) What is the 4th ? _____</p> <p>6) What is the 6th ? _____</p>		

In the Key of G...

- 1) What is the 3rd ? _____
- 2) What is the 5th ? _____
- 3) What is the 7th ? _____
- 4) What is the 2nd ? _____
- 5) What is the 4th ? _____
- 6) What is the 6th ? _____

In the Key of D...

- 1) What is the 3rd ? _____
- 2) What is the 5th ? _____
- 3) What is the 7th ? _____
- 4) What is the 2nd ? _____
- 5) What is the 4th ? _____
- 6) What is the 6th ? _____

In the Key of A...

- 1) What is the 3rd ? _____
- 2) What is the 5th ? _____
- 3) What is the 7th ? _____
- 4) What is the 2nd ? _____
- 5) What is the 4th ? _____
- 6) What is the 6th ? _____

In the Key of E...

- 1) What is the 3rd ? _____
- 2) What is the 5th ? _____
- 3) What is the 7th ? _____
- 4) What is the 2nd ? _____
- 5) What is the 4th ? _____
- 6) What is the 6th ? _____

In the Key of B...

- 1) What is the 3rd ? _____
- 2) What is the 5th ? _____
- 3) What is the 7th ? _____
- 4) What is the 2nd ? _____
- 5) What is the 4th ? _____
- 6) What is the 6th ? _____

In the Key of F#...

- 1) What is the 3rd ? _____
- 2) What is the 5th ? _____
- 3) What is the 7th ? _____
- 4) What is the 2nd ? _____
- 5) What is the 4th ? _____
- 6) What is the 6th ? _____

More Challenging Diatonic Intervals

Use your knowledge of major scales and key signatures to fill in the correct note corresponding to the diatonic interval asked for. These exercises use scales that have 4 or more sharps or flats in their key signature. These would be the Ab, E, Db, B, Gb, & F# scales.

✓ Check your answers with the Answer Key on page 172.

- | | |
|--|--|
| 1) In Ab, what is the 3 rd ? _____ | 21) In Db, what is the 3 rd ? _____ |
| 2) In E, what is the 5 th ? _____ | 22) In B, what is the 7 th ? _____ |
| 3) In Db, what is the 2 nd ? _____ | 23) In Gb, what is the 4 th ? _____ |
| 4) In B, what is the 4 th ? _____ | 24) In F#, what is the 2 nd ? _____ |
| 5) In Gb, what is the 3 rd ? _____ | 25) In Ab, what is the 4 th ? _____ |
| 6) The 7 th in F# is _____ | 26) The 2 nd in E is _____ |
| 7) The 2 nd in Ab is _____ | 27) The 4 th in Db is _____ |
| 8) The 6 th in E is _____ | 28) The 2 nd in B is _____ |
| 9) The 7 th in Db is _____ | 29) The 2 nd in Gb is _____ |
| 10) The 3 rd in B is _____ | 30) The 4 th in F# is _____ |
| 11) In Gb, what is the 6 th ? _____ | 31) In Ab, what is the 6 th ? _____ |
| 12) In F#, what is the 5 th ? _____ | 32) In E, what is the 7 th ? _____ |
| 13) In Ab, what is the 5 th ? _____ | 33) In Db, what is the 6 th ? _____ |
| 14) In E, what is the 4 th ? _____ | 34) In B, what is the 6 th ? _____ |
| 15) In Db, what is the 4 th ? _____ | 35) In Gb, what is the 5 th ? _____ |
| 16) The 5 th in B is _____ | 36) The 6 th in F# is _____ |
| 17) The 7 th in Gb is _____ | 37) The 3 rd in Ab is _____ |
| 18) The 3 rd in F# is _____ | 38) The 5 th in E is _____ |
| 19) The 7 th in Ab is _____ | 39) The 5 th in Db is _____ |
| 20) The 3 rd in E is _____ | 40) The 4 th in B is _____ |

Harmonic Intervals Worksheet

HARMONIC intervals are intervals that have been raised or lowered from their natural major scale (diatonic) position. Fill in the correct note corresponding to the harmonic interval asked for. Don't substitute in the enharmonic equivalent of the note. For example, the correct answer for the minor 2nd in Eb is Fb, not E. Refer to page 54 of the lesson book for more explanation. Remember, if a major interval (2nd, 3rd, 6th & 7th) is lowered by a half step it is called MINOR (min.). If a major interval is raised a half step then it is called AUGMENTED (aug.). If a perfect interval (4th, 5th & Octave) is lowered a half step it is called DIMINISHED (dim.). If a perfect interval is raised a half step it is called AUGMENTED (aug.).

✓ Check your answers with the Answer Key on page 173.

- | | |
|---|---|
| 1) In C, what is the dim. 5 th ? <u>Gb</u> | 21) In A, what is the min. 7 th ? _____ |
| 2) In F, what is the min. 3 rd ? <u>Ab</u> | 22) In C, what is the aug. 5 th ? _____ |
| 3) In G, what is the aug. 4 th ? _____ | 23) In F, what is the aug. 4 th ? _____ |
| 4) In Bb, what is the min. 2 nd ? _____ | 24) In G, what is the aug. 5 th ? _____ |
| 5) In D, what is the aug. 5 th ? _____ | 25) In Bb, what is the min. 7 th ? _____ |
| 6) The min 7 th in Eb is _____ | 26) The min. 2 nd in D is _____ |
| 7) The min 2 nd in A is _____ | 27) The aug. 2 nd in Eb is _____ |
| 8) The aug. 6 th in C is _____ | 28) The min. 3 rd in A is _____ |
| 9) The min. 7 th in F is _____ | 29) The min. 7 th in C is _____ |
| 10) The min. 3 rd in G is _____ | 30) The aug. 2 nd in F is _____ |
| 11) In Bb, what is the aug. 6 th ? _____ | 31) In G, what is the dim. 5 th ? _____ |
| 12) In D, what is the dim. 5 th ? _____ | 32) In Bb, what is the aug. 5 th ? _____ |
| 13) In Eb, what is the min. 3 rd ? _____ | 33) In D, what is the min. 3 rd ? _____ |
| 14) In A, what is the aug. 4 th ? _____ | 34) In Eb, what is the min. 2 nd ? _____ |
| 15) In C, what is the min. 2 nd ? _____ | 35) In A, what is the dim. 5 th ? _____ |
| 16) The min. 2 nd in F is _____ | 36) The min. 3 rd in C is _____ |
| 17) The min. 7 th in G is _____ | 37) The aug. 5 th in F is _____ |
| 18) The min. 3 rd in Bb is _____ | 38) The aug. 2 nd in G is _____ |
| 19) The min. 7 th in D is _____ | 39) The dim. 5 th in Bb is _____ |
| 20) The aug. 5 th in Eb is _____ | 40) The aug. 2 nd in D is _____ |

Harmonic Intervals by Key Worksheet

Using your knowledge of major scales and key signatures fill in the correct note corresponding to the harmonic interval asked for. The exercises are grouped into keys.

✓ Check your answers with the Answer Key on page 174.

In the Key of C...

- 1) What is the minor 3rd? _____
- 2) What is the minor 7th? _____
- 3) What is the aug. 5th? _____
- 4) What is the minor 2nd? _____
- 5) What is the aug. 4th? _____
- 6) What is the aug. 2nd? _____
- 7) What is the dim. 5th? _____

In the Key of F...

- 1) What is the minor 3rd? _____
- 2) What is the minor 7th? _____
- 3) What is the aug. 5th? _____
- 4) What is the minor 2nd? _____
- 5) What is the aug. 4th? _____
- 6) What is the aug. 2nd? _____
- 7) What is the dim. 5th? _____

In the Key of Bb...

- 1) What is the minor 3rd? _____
- 2) What is the minor 7th? _____
- 3) What is the aug. 5th? _____
- 4) What is the minor 2nd? _____
- 5) What is the aug. 4th? _____
- 6) What is the aug. 2nd? _____
- 7) What is the dim. 5th? _____

In the Key of Eb...

- 1) What is the minor 3rd? _____
- 2) What is the minor 7th? _____
- 3) What is the aug. 5th? _____
- 4) What is the minor 2nd? _____
- 5) What is the aug. 4th? _____
- 6) What is the aug. 2nd? _____
- 7) What is the dim. 5th? _____

In the Key of Ab...

- 1) What is the minor 3rd? _____
- 2) What is the minor 7th? _____
- 3) What is the aug. 5th? _____
- 4) What is the minor 2nd? _____
- 5) What is the aug. 4th? _____
- 6) What is the aug. 2nd? _____
- 7) What is the dim. 5th? _____

In the Key of Db...

- 1) What is the minor 3rd? _____
- 2) What is the minor 7th? _____
- 3) What is the aug. 5th? _____
- 4) What is the minor 2nd? _____
- 5) What is the aug. 4th? _____
- 6) What is the aug. 2nd? _____
- 7) What is the dim. 5th? _____

In the Key of Gb...

- 1) What is the minor 3rd? _____
- 2) What is the minor 7th? _____
- 3) What is the aug. 5th? _____
- 4) What is the minor 2nd? _____
- 5) What is the aug. 4th? _____
- 6) What is the aug. 2nd? _____
- 7) What is the dim. 5th? _____

In the Key of G...

- 1) What is the minor 3rd? _____
- 2) What is the minor 7th? _____
- 3) What is the aug. 5th? _____
- 4) What is the minor 2nd? _____
- 5) What is the aug. 4th? _____
- 6) What is the aug. 2nd? _____
- 7) What is the dim. 5th? _____

In the Key of D...

- 1) What is the minor 3rd? _____
- 2) What is the minor 7th? _____
- 3) What is the aug. 5th? _____
- 4) What is the minor 2nd? _____
- 5) What is the aug. 4th? _____
- 6) What is the aug. 2nd? _____
- 7) What is the dim. 5th? _____

In the Key of A...

- 1) What is the minor 3rd? _____
- 2) What is the minor 7th? _____
- 3) What is the aug. 5th? _____
- 4) What is the minor 2nd? _____
- 5) What is the aug. 4th? _____
- 6) What is the aug. 2nd? _____
- 7) What is the dim. 5th? _____

In the Key of E...

- 1) What is the minor 3rd? _____
- 2) What is the minor 7th? _____
- 3) What is the aug. 5th? _____
- 4) What is the minor 2nd? _____
- 5) What is the aug. 4th? _____
- 6) What is the aug. 2nd? _____
- 7) What is the dim. 5th? _____

In the Key of B...

- 1) What is the minor 3rd? _____
- 2) What is the minor 7th? _____
- 3) What is the aug. 5th? _____
- 4) What is the minor 2nd? _____
- 5) What is the aug. 4th? _____
- 6) What is the aug. 2nd? _____
- 7) What is the dim. 5th? _____

In the Key of F#...

- 1) What is the minor 3rd? _____
- 2) What is the minor 7th? _____
- 3) What is the aug. 5th? _____
- 4) What is the minor 2nd? _____
- 5) What is the aug. 4th? _____
- 6) What is the aug. 2nd? _____
- 7) What is the dim. 5th? _____

The Most Important Harmonic Intervals

Certain harmonic intervals are more commonly used than others. When building chords and soloing, the harmonic intervals of the minor 3rd, the minor 7th, the augmented 5th and the diminished 5th are important to know. Here is a table to help you learn these important harmonic intervals by associating them by key.

✓ Check your answers with the Answer Key on page 176.

	<p>In the Key of C...</p> <p>1) What is the minor 3rd? <u> Eb </u></p> <p>2) What is the minor 7th? <u> </u></p> <p>3) What is the aug. 5th? <u> G# </u></p> <p>4) What is the dim. 5th? <u> </u></p>	
<p>In the Key of F...</p> <p>1) What is the minor 3rd? <u> </u></p> <p>2) What is the minor 7th? <u> </u></p> <p>3) What is the aug. 5th? <u> </u></p> <p>4) What is the dim. 5th? <u> </u></p>	<p>In the Key of Bb...</p> <p>1) What is the minor 3rd? <u> </u></p> <p>2) What is the minor 7th? <u> </u></p> <p>3) What is the aug. 5th? <u> </u></p> <p>4) What is the dim. 5th? <u> </u></p>	<p>In the Key of Eb...</p> <p>1) What is the minor 3rd? <u> </u></p> <p>2) What is the minor 7th? <u> </u></p> <p>3) What is the aug. 5th? <u> </u></p> <p>4) What is the dim. 5th? <u> </u></p>
<p>In the Key of Ab...</p> <p>1) What is the minor 3rd? <u> </u></p> <p>2) What is the minor 7th? <u> </u></p> <p>3) What is the aug. 5th? <u> </u></p> <p>4) What is the dim. 5th? <u> </u></p>	<p>In the Key of Db...</p> <p>1) What is the minor 3rd? <u> </u></p> <p>2) What is the minor 7th? <u> </u></p> <p>3) What is the aug. 5th? <u> </u></p> <p>4) What is the dim. 5th? <u> </u></p>	<p>In the Key of Gb...</p> <p>1) What is the minor 3rd? <u> </u></p> <p>2) What is the minor 7th? <u> </u></p> <p>3) What is the aug. 5th? <u> </u></p> <p>4) What is the dim. 5th? <u> </u></p>
<p>In the Key of G...</p> <p>1) What is the minor 3rd? <u> </u></p> <p>2) What is the minor 7th? <u> </u></p> <p>3) What is the aug. 5th? <u> </u></p> <p>4) What is the dim. 5th? <u> </u></p>	<p>In the Key of D...</p> <p>1) What is the minor 3rd? <u> </u></p> <p>2) What is the minor 7th? <u> </u></p> <p>3) What is the aug. 5th? <u> </u></p> <p>4) What is the dim. 5th? <u> </u></p>	<p>In the Key of A...</p> <p>1) What is the minor 3rd? <u> </u></p> <p>2) What is the minor 7th? <u> </u></p> <p>3) What is the aug. 5th? <u> </u></p> <p>4) What is the dim. 5th? <u> </u></p>
<p>In the Key of E...</p> <p>1) What is the minor 3rd? <u> </u></p> <p>2) What is the minor 7th? <u> </u></p> <p>3) What is the aug. 5th? <u> </u></p> <p>4) What is the dim. 5th? <u> </u></p>	<p>In the Key of B...</p> <p>1) What is the minor 3rd? <u> </u></p> <p>2) What is the minor 7th? <u> </u></p> <p>3) What is the aug. 5th? <u> </u></p> <p>4) What is the dim. 5th? <u> </u></p>	<p>In the Key of F#...</p> <p>1) What is the minor 3rd? <u> </u></p> <p>2) What is the minor 7th? <u> </u></p> <p>3) What is the aug. 5th? <u> </u></p> <p>4) What is the dim. 5th? <u> </u></p>

Ultimate Interval Challenge

This worksheet includes both diatonic and harmonic intervals in all 12 keys. The questions are asked in various forms. If you can pass this worksheet, then you have officially conquered any interval that you are likely ever to have to deal with. This is university level music theory. When you are building chords or soloing, your knowledge of these intervals will give you a great advantage.

✓ Check your answers with the Answer Key on page 177.

- | | | | |
|---|-----------|--|-------|
| 1) In C, what is the augmented 2 nd ? | <u>D#</u> | 21) In G, what is the diminished 5 th ? | _____ |
| 2) In F, what is the perfect 4 th ? | <u>Bb</u> | 22) In D, what is the 7 th ? | _____ |
| 3) In Bb, what is the minor 6 th ? | _____ | 23) In A, what is the augmented 4 th ? | _____ |
| 4) In Eb, what is the major 7 th ? | _____ | 24) In E, what is the major 7 th ? | _____ |
| 5) In Ab, what is the diminished 5 th ? | _____ | 25) In B, what is the minor 3 rd ? | _____ |
| 6) The 3 rd in Db is | _____ | 26) The 7 th in F# is | _____ |
| 7) The augmented 2 nd in Gb is | _____ | 27) The diminished 5 th in C is | _____ |
| 8) The major 6 th in G is | _____ | 28) The major 2 nd in F is | _____ |
| 9) The minor 7 th in D is | _____ | 29) The minor 3 rd in Bb is | _____ |
| 10) The 5 th in A is | _____ | 30) The perfect 5 th in Eb is | _____ |
| 11) In E, what is the minor 2 nd ? | _____ | 31) In Ab, what is the augmented 2 nd ? | _____ |
| 12) In B, what is the major 7 th ? | _____ | 32) In Db, what is the 4 th ? | _____ |
| 13) In F#, what is the diminished 5 th ? | _____ | 33) In Gb, what is the minor 3 rd ? | _____ |
| 14) In C, what is the perfect 4 th ? | _____ | 34) In G, what is the 7 th ? | _____ |
| 15) In F, what is the minor 7 th ? | _____ | 35) In D, what is the augmented 4 th ? | _____ |
| 16) The major 2 nd in Bb is | _____ | 36) The minor 3 rd in A is | _____ |
| 17) The augmented 4 th in Eb is | _____ | 37) The major 6 th in E is | _____ |
| 18) The 6 th in Ab is | _____ | 38) The augmented 2 nd in B is | _____ |
| 19) The minor 7 th in Db is | _____ | 39) The 3 rd in F# is | _____ |
| 20) The perfect 5 th in Gb is | _____ | 40) The octave in C is | _____ |

Pentatonic Scales Worksheet

A PENTATONIC SCALE is a five note scale derived from the major scale. It uses the first, second, third, fifth and sixth steps of the major scale. Here is a C pentatonic scale built from the C major scale.

C Pentatonic Scale

Major Scale Steps 1 2 3 5 6

Fill in the pentatonic scale notes for each of the keys given using your knowledge of major scales and keys. Filling out this worksheet numerous times helps build the necessary memory recognition of these pentatonic scales.

✓ Check your answers with the Answer Key on page 178.

C _____

SHARP KEYS

G _____

D _____

A _____

E _____

B _____

F# _____

FLAT KEYS

F _____

Bb _____

Eb _____

Ab _____

Db _____

Gb _____

Pentatonic Scales Ultimate Mix Up

Fill in the pentatonic scale notes for each key by looking at the key signature. Remember, the five notes of the pentatonic scale correspond to the 1st, 2nd, 3rd, 5th and 6th steps of the major scale. Some hints have been given along the way to help you spell the scales.

✓ Check your answers with the Answer Key on page 179.

Key Signature

What's the Pentatonic Scale?

1)

 D F#

2)

 F#

3)

4)

 G#

5)

6)

 C

7)

8)

 C

9)

10)

 C

11)

12)

 F

13)

Triad Examples in C

- 1) A **C Major** triad would use the 1st, 3rd and 5th scale tones from the C major scale. So, a C Major triad would be C, E and G.
- 2) A **C Minor** triad would use the same scale tones, but we would need to lower the 3rd a half step. So, a C Minor triad would be C, **Eb**, and G.
- 3) A **C Augmented** triad would require us to raise the 5th step up a half step. So, a C Augmented triad would be C, E, and **G#**.
- 4) A **C Diminished** triad would have us lower the 3rd and the 5th scale tone down a half step. This would make a C Diminished triad be C, **Eb**, and **Gb**.

Triad Worksheet

Directions: Fill in the proper letter names for each triad.

✓ Check your answers at www.LearnandMasterGuitar.com/answerkey

- | | | | | | | | |
|-----------------|--------------|---------------|--------------|-------------------|-------------|-------------|-------------|
| 1) F Minor | <u> F </u> | <u> Ab </u> | <u> C </u> | 11) F Major | <u> </u> | <u> </u> | <u> </u> |
| 2) G Major | <u> G </u> | <u> B </u> | <u> D </u> | 12) G Minor | <u> </u> | <u> </u> | <u> </u> |
| 3) C Diminished | <u> </u> | <u> </u> | <u> </u> | 13) Bb Diminished | <u> </u> | <u> </u> | <u> </u> |
| 4) Bb Augmented | <u> </u> | <u> </u> | <u> </u> | 14) D Augmented | <u> </u> | <u> </u> | <u> </u> |
| 5) Eb Major | <u> </u> | <u> </u> | <u> </u> | 15) Eb Minor | <u> </u> | <u> </u> | <u> </u> |
| 6) D Minor | <u> </u> | <u> </u> | <u> </u> | 16) A Major | <u> </u> | <u> </u> | <u> </u> |
| 7) A Diminished | <u> </u> | <u> </u> | <u> </u> | 17) Ab Minor | <u> </u> | <u> </u> | <u> </u> |
| 8) Ab Major | <u> </u> | <u> </u> | <u> </u> | 18) E Augmented | <u> </u> | <u> </u> | <u> </u> |
| 9) E Minor | <u> </u> | <u> </u> | <u> </u> | 19) Db Major | <u> </u> | <u> </u> | <u> </u> |
| 10) C Minor | <u> </u> | <u> </u> | <u> </u> | 20) B Minor | <u> </u> | <u> </u> | <u> </u> |

Session 13 Assignment

- Practice all of the Pentatonic Forms with Blues Notes in all keys for the full range of the guitar. (page 72)
- Memorize the Blues Chord Progression. (pages 72-73)
- Memorize the four Triad Types and complete the Triad Practice Worksheet. (pages 73-74)
- Play Jammin the Blues and Johnny's E Blues with the Jam Along CD. Practice playing the chords and soloing using the pentatonic forms with blues notes. (page 75)

Triads by Key Worksheet

Fill out the appropriate scale tones in each triad. They are grouped according to key. Some notes have been filled in to help you out. Use double sharps or flats as needed. Remember, when spelling chords don't give the enharmonic equivalent of a note. For example, when spelling chords, a half-step below a C is a Cb, not a B.

Triad Types	Formulas
Major	1 - 3 - 5
Minor	1 - b3 - 5
Augmented	1 - 3 - #5
Diminished	1 - b3 - b5

✓ Check your answers with the Answer Key on page 180.

C Major	<u>C</u>	<u>E</u>	<u>G</u>	Eb Major	___	___	___
C Minor	<u>C</u>	<u>Eb</u>	<u>G</u>	Eb Minor	___	___	___
C Augmented	___	___	<u>G#</u>	Eb Augmented	___	___	___
C Diminished	___	<u>Eb</u>	<u>Gb</u>	Eb Diminished	___	___	<u>Bbb</u>
F Major	<u>F</u>	___	___	A Major	___	___	___
F Minor	___	<u>Ab</u>	___	A Minor	___	___	___
F Augmented	___	___	<u>C#</u>	A Augmented	___	___	<u>E#</u>
F Diminished	___	___	<u>Cb</u>	A Diminished	___	___	___
G Major	___	___	___	Ab Major	___	___	___
G Minor	___	___	___	Ab Minor	___	<u>Cb</u>	___
G Augmented	___	___	<u>D#</u>	Ab Augmented	___	___	___
G Diminished	___	<u>Bb</u>	___	Ab Diminished	___	___	___
Bb Major	___	___	___	E Major	___	___	___
Bb Minor	___	<u>Db</u>	___	E Minor	___	___	___
Bb Augmented	___	___	___	E Augmented	___	___	___
Bb Diminished	___	___	<u>Fb</u>	E Diminished	___	___	___
D Major	___	<u>F#</u>	___	Db Major	___	___	___
D Minor	___	___	___	Db Minor	___	___	___
D Augmented	___	___	___	Db Augmented	___	___	___
D Diminished	___	___	___	Db Diminished	___	___	<u>Abb</u>

Triads Worksheet

Fill in the triad notes for each of the chords using your knowledge of triad formulas and keys. Filling out this worksheet numerous times will help build the necessary memory recognition of these triads.

✓ Check your answers with the Answer Key on page 181.

<u>Triad Types</u>	<u>Formulas</u>
Major	1 - 3 - 5
Minor	1 - b3 - 5
Augmented	1 - 3 - #5
Diminished	1 - b3 - b5

1) C Minor _____

2) F Major _____

3) G Minor _____

4) Bb Diminished _____

5) D Augmented _____

6) Eb Minor _____

7) A Major _____

8) Ab Minor _____

9) E Augmented _____

10) Db Major _____

11) B Minor _____

12) Gb Major _____

13) F# Minor _____

14) C Major _____

15) F Diminished _____

16) G Augmented _____

17) Bb Minor _____

18) D Diminished _____

19) Eb Augmented _____

20) A Minor _____

21) F Minor _____

22) G Major _____

23) C Diminished _____

24) Bb Augmented _____

25) Eb Major _____

26) D Minor _____

27) A Diminished _____

28) Ab Major _____

29) E Minor _____

30) Eb Diminished _____

31) E Major _____

32) Db Minor _____

33) B Major _____

34) Gb Minor _____

35) F# Major _____

36) C Augmented _____

37) F Augmented _____

38) G Diminished _____

39) Bb Major _____

40) D Major _____

Harmonized Major Scales Worksheet

A HARMONIZED MAJOR SCALE is a specific pattern of chords that are derived from the major scale. For a particular key, triads are built on each step of the major scale according to the key signature. The resulting triads come in a predictable pattern for every key. Triads built on the 1st, 4th & 5th scale steps become MAJOR CHORDS and are noted with capitalized roman numerals. Triads built on the 2nd, 3rd & 6th scale steps become MINOR CHORDS and are notated with lower case roman numerals. The triad built on the 7th scale step is a DIMINISHED CHORD which is also notated with lower case roman numerals. This pattern of Major, Minor & Diminished chords is consistent in every key.

Using your knowledge of key signatures, fill in the correct triad. Some of the answers are already filled in to help you.

✓ Check your answers with the Answer Key on page 182.

1) In C, what is the V chord?	<u>G</u>	What notes are in it?	<u>G</u>	<u>B</u>	<u>D</u>
2) In F, what is the iii chord?	<u>Am</u>	What notes are in it?	<u>A</u>	<u>C</u>	<u>E</u>
3) In G, what is the vi chord?	_____	What notes are in it?	_____	<u>G</u>	_____
4) In Bb, what is the IV chord?	_____	What notes are in it?	_____	<u>G</u>	_____
5) In D, what is the I chord?	_____	What notes are in it?	_____	_____	_____
6) The ii chord in Eb is	_____	What notes are in it?	_____	_____	_____
7) The ii chord in A is	_____	What notes are in it?	_____	_____	_____
8) The vi chord in C is	_____	What notes are in it?	_____	_____	_____
9) The vii chord in F is	<u>E dim</u>	What notes are in it?	_____	<u>G</u>	_____
10) The iii chord in G is	_____	What notes are in it?	_____	_____	_____
11) In Bb, what is the vi chord?	_____	What notes are in it?	<u>G</u>	_____	_____
12) In D, what is the V chord?	_____	What notes are in it?	_____	_____	_____
13) In Eb, what is the iii chord?	_____	What notes are in it?	<u>G</u>	_____	_____
14) In A, what is the IV chord?	_____	What notes are in it?	_____	_____	_____
15) In C, what is the ii chord?	_____	What notes are in it?	_____	_____	_____
16) The ii chord in F is	_____	What notes are in it?	<u>G</u>	_____	_____
17) The I chord in G is	_____	What notes are in it?	<u>G</u>	_____	_____
18) The iii chord in Bb is	_____	What notes are in it?	_____	_____	_____
19) The vii chord in D is	_____	What notes are in it?	_____	_____	<u>G</u>
20) The V chord in Eb is	_____	What notes are in it?	_____	_____	_____

Seventh Chords

A SEVENTH CHORD is a combination of FOUR notes played together.

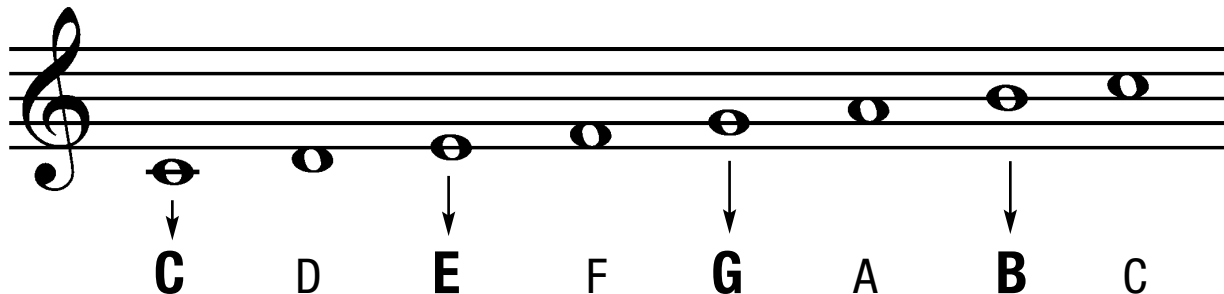

There are SIX common types of seventh chords. With the addition of the seventh scale step, the number of ways all these tones can be adjusted adds up to more chord variations. Although these are not all of the possible combinations, the following chart shows the most commonly used forms.

<u>Seventh Types</u>	<u>Formulas</u>	<u>Abbreviations</u>
Major 7th	1 - 3 - 5 - 7	Cmaj7, C ^Δ 7
Minor 7th	1 - b3 - 5 - b7	Cmin7, Cm7, C-7
Dominant 7th	1 - 3 - 5 - b7	C7, C7, G7, D7
Augmented 7th	1 - 3 - #5 - b7	Caug7, C+7
Diminished 7th	1 - b3 - b5 - bb7	Cdim7, C ^o , C ^o 7
Half-Dim. 7th	1 - b3 - b5 - b7	C half-dim, C ^o 7

Seventh Chord Worksheet

Directions: Fill out the appropriate scale tones in each seventh chord. Remember to adjust them as needed to fulfill the formula for the triad type. Use double sharps or flats as needed.

✓ Check your answers at www.LearnandMasterGuitar.com/answerkey

- | | | | | | | | | | |
|--------------------|-------|-------|-------|-------|-----------------------|-------|-------|-------|-------|
| 1) Gmaj7 | _____ | _____ | _____ | _____ | 11) Bbm7 | _____ | _____ | _____ | _____ |
| 2) Cm7 | _____ | _____ | _____ | _____ | 12) Ebmaj7 | _____ | _____ | _____ | _____ |
| 3) F+7 | _____ | _____ | _____ | _____ | 13) Ab+7 | _____ | _____ | _____ | _____ |
| 4) Bb7 | _____ | _____ | _____ | _____ | 14) C# ^o 7 | _____ | _____ | _____ | _____ |
| 5) Eb ^o | _____ | _____ | _____ | _____ | 15) Gbmaj7 | _____ | _____ | _____ | _____ |
| 6) Abm7 | _____ | _____ | _____ | _____ | 16) Bmin7 | _____ | _____ | _____ | _____ |
| 7) Db7 | _____ | _____ | _____ | _____ | 17) E ^o 7 | _____ | _____ | _____ | _____ |
| 8) F#min7 | _____ | _____ | _____ | _____ | 18) A7 | _____ | _____ | _____ | _____ |
| 9) Bau7 | _____ | _____ | _____ | _____ | 19) Dm7 | _____ | _____ | _____ | _____ |
| 10) E7 | _____ | _____ | _____ | _____ | 20) Gau7 | _____ | _____ | _____ | _____ |

Seventh Chords by Key Worksheet

Fill out the appropriate scale tones in each seventh chord. They are grouped according to key. Some notes have been filled in to help you out. Use double sharps or flats as needed. Remember, when spelling chords don't give the enharmonic equivalent of a note. For example, when spelling chords, a half step below a C is a Cb, not a B.

Seventh Types	Formulas
Major 7th	1 - 3 - 5 - 7
Minor 7th	1 - b3 - 5 - b7
Dominant 7th	1 - 3 - 5 - b7
Augmented 7th	1 - 3 - #5 - b7
Diminished 7th	1 - b3 - b5 - bb7
Half-Dim. 7th	1 - b3 - b5 - b7

✓ Check your answers with the Answer Key on page 183.

C Major 7 th	<u>C</u>	<u>E</u>	<u>G</u>	<u>B</u>	Bb Major 7 th	_____	_____	_____	_____
C Minor 7 th	<u>C</u>	<u>Eb</u>	_____	<u>Bb</u>	Bb Minor 7 th	_____	_____	_____	_____
C Dominant 7 th	_____	<u>E</u>	_____	_____	Bb Dominant 7 th	_____	_____	_____	_____
C Augmented 7 th	_____	_____	<u>G#</u>	_____	Bb Augmented 7 th	_____	_____	<u>F#</u>	_____
C Diminished 7 th	_____	<u>Eb</u>	<u>Gb</u>	<u>Bbb</u>	Bb Diminished 7 th	_____	_____	_____	_____
C Half-Dim. 7 th	_____	<u>Eb</u>	_____	<u>Bb</u>	Bb Half-Dim. 7 th	_____	_____	_____	_____
F Major 7 th	_____	_____	_____	<u>E</u>	D Major 7 th	_____	_____	_____	<u>C#</u>
F Minor 7 th	_____	<u>Ab</u>	_____	_____	D Minor 7 th	_____	_____	_____	_____
F Dominant 7 th	_____	_____	_____	_____	D Dominant 7 th	_____	_____	_____	_____
F Augmented 7 th	_____	_____	<u>C#</u>	_____	D Augmented 7 th	_____	_____	_____	_____
F Diminished 7 th	_____	_____	<u>Cb</u>	<u>Ebb</u>	D Diminished 7 th	_____	_____	_____	_____
F Half-Dim. 7 th	_____	_____	_____	<u>Eb</u>	D Half-Dim. 7 th	_____	_____	_____	_____
G Major 7 th	_____	_____	_____	<u>F#</u>	Eb Major 7 th	_____	_____	_____	_____
G Minor 7 th	_____	_____	_____	_____	Eb Minor 7 th	_____	_____	_____	_____
G Dominant 7 th	_____	_____	_____	_____	Eb Dominant 7 th	_____	_____	_____	_____
G Augmented 7 th	_____	_____	_____	_____	Eb Augmented 7 th	_____	_____	_____	_____
G Diminished 7 th	_____	_____	_____	_____	Eb Diminished 7 th	_____	_____	_____	_____
G Half-Dim. 7 th	_____	_____	_____	_____	Eb Half-Dim. 7 th	_____	_____	_____	_____

A Major 7 th	_____	_____	_____	<u>G#</u>	B Major 7 th	_____	_____	_____	<u>A#</u>
A Minor 7 th	_____	_____	_____	_____	B Minor 7 th	_____	_____	_____	_____
A Dominant 7 th	_____	_____	_____	_____	B Dominant 7 th	_____	_____	_____	_____
A Augmented 7 th	_____	_____	_____	_____	B Augmented 7 th	_____	_____	_____	_____
A Diminished 7 th	_____	_____	_____	_____	B Diminished 7 th	_____	_____	_____	_____
A Half-Dim. 7 th	_____	_____	_____	_____	B Half-Dim. 7 th	_____	_____	_____	_____
Ab Major 7 th	_____	_____	_____	_____	Gb Major 7 th	_____	_____	_____	_____
Ab Minor 7 th	_____	_____	_____	_____	Gb Minor 7 th	_____	<u>Bbb</u>	_____	_____
Ab Dominant 7 th	_____	_____	_____	_____	Gb Dominant 7 th	_____	_____	_____	_____
Ab Augmented 7 th	_____	_____	<u>E</u>	_____	Gb Augmented 7 th	_____	_____	_____	_____
Ab Diminished 7 th	_____	_____	_____	_____	Gb Diminished 7 th	_____	_____	_____	_____
Ab Half-Dim. 7 th	_____	_____	_____	_____	Gb Half-Dim. 7 th	_____	_____	_____	_____
E Major 7 th	_____	_____	_____	_____	F# Major 7 th	_____	_____	_____	<u>E#</u>
E Minor 7 th	_____	_____	_____	_____	F# Minor 7 th	_____	_____	_____	_____
E Dominant 7 th	_____	_____	_____	_____	F# Dominant 7 th	_____	_____	_____	_____
E Augmented 7 th	_____	_____	_____	_____	F# Augmented 7 th	_____	_____	_____	_____
E Diminished 7 th	_____	_____	_____	_____	F# Diminished 7 th	_____	_____	_____	_____
E Half-Dim. 7 th	<u>E</u>	_____	_____	_____	F# Half-Dim. 7 th	_____	_____	_____	_____
Db Major 7 th	_____	_____	_____	_____	<p>Aren't you glad there aren't 25 major scale keys!</p>				
Db Minor 7 th	_____	_____	_____	_____					
Db Dominant 7 th	_____	_____	_____	_____					
Db Augmented 7 th	_____	_____	_____	_____					
Db Diminished 7 th	_____	_____	_____	_____					
Db Half-Dim. 7 th	_____	_____	_____	_____					

Seventh Chords Worksheet

Chords are abbreviated when used in song chord progressions. The following are various abbreviations commonly used in songs. They are listed below as if they were in the key of C for illustration purposes.

<u>Seventh Types</u>	<u>Formulas</u>	<u>Abbreviations</u>
Major 7th	1 - 3 - 5 - 7	Cmaj ⁷ , C ^{Δ7}
Minor 7th	1 - b3 - 5 - b7	Cmin ⁷ , Cm ⁷ , C- ⁷
Dominant 7th	1 - 3 - 5 - b7	C7, C ⁷ , G7, D7
Augmented 7th	1 - 3 - #5 - b7	Caug ⁷ , C+ ⁷
Diminished 7th	1 - b3 - b5 - bb7	Cdim ⁷ , C ^o , C ^{o7}
Half-Dim. 7th	1 - b3 - b5 - b7	C half-dim, C ^ø

Fill in the notes for each of the seventh chords.

✓ Check your answers with the Answer Key on page 185.

- | | | | | | | | | | |
|---------------------|-------|-------|-------|-------|---------------------|-------|-------|-------|-------|
| 1) Cm7 | _____ | _____ | _____ | _____ | 15) F7 | _____ | _____ | _____ | _____ |
| 2) Fmaj7 | _____ | _____ | _____ | _____ | 16) Gm7 | _____ | _____ | _____ | _____ |
| 3) G7 | _____ | _____ | _____ | _____ | 17) Bbmaj7 | _____ | _____ | _____ | _____ |
| 4) Bb ^{o7} | _____ | _____ | _____ | _____ | 18) D7 | _____ | _____ | _____ | _____ |
| 5) Daug7 | _____ | _____ | _____ | _____ | 19) Ebm7 | _____ | _____ | _____ | _____ |
| 6) Eb7 | _____ | _____ | _____ | _____ | 20) Amaj7 | _____ | _____ | _____ | _____ |
| 7) Am7 | _____ | _____ | _____ | _____ | 21) Fm7 | _____ | _____ | _____ | _____ |
| 8) Ab ^{Δ7} | _____ | _____ | _____ | _____ | 22) G+7 | _____ | _____ | _____ | _____ |
| 9) E+7 | _____ | _____ | _____ | _____ | 23) C ^{o7} | _____ | _____ | _____ | _____ |
| 10) Dbmaj7 | _____ | _____ | _____ | _____ | 24) Bb half-dim | _____ | _____ | _____ | _____ |
| 11) Bm7 | _____ | _____ | _____ | _____ | 25) Ebaug7 | _____ | _____ | _____ | _____ |
| 12) Gb7 | _____ | _____ | _____ | _____ | 26) Dmaj7 | _____ | _____ | _____ | _____ |
| 13) F#m7 | _____ | _____ | _____ | _____ | 27) A ^ø | _____ | _____ | _____ | _____ |
| 14) C ^ø | _____ | _____ | _____ | _____ | 28) Ab7 | _____ | _____ | _____ | _____ |

Ninth Chords by Key

Worksheet

Fill out the appropriate scale tones in each ninth chord. They are grouped according to key. Some notes have been filled in to help you out. Use double sharps or flats as needed. Remember, when spelling chords do not give the enharmonic equivalent of a note. For example, when spelling chords, a half step below a C is a Cb, not a B.

Ninth Types	Formulas
Major 9th	1 - 3 - 5 - 7 - 9
Minor 9th	1 - b3 - 5 - b7 - 9
Dominant 9th	1 - 3 - 5 - b7 - 9

✓ Check your answers with the Answer Key on page 186.

C Major 9 th	_____	<u>E</u>	_____	<u>B</u>	_____
C Minor 9 th	<u>C</u>	<u>E^b</u>	<u>G</u>	<u>B^b</u>	<u>D</u>
C Dominant 9 th	_____	_____	<u>G</u>	_____	_____

G Major 9 th	<u>G</u>	_____	_____	_____	_____
G Minor 9 th	_____	<u>B^b</u>	_____	_____	_____
G Dominant 9 th	_____	_____	<u>D</u>	_____	_____
D Major 9 th	_____	_____	_____	<u>C[#]</u>	_____
D Minor 9 th	_____	_____	_____	_____	<u>E</u>
D Dominant 9 th	_____	_____	_____	<u>C</u>	_____
A Major 9 th	_____	_____	<u>E</u>	_____	_____
A Minor 9 th	_____	<u>C</u>	_____	_____	_____
A Dominant 9 th	<u>A</u>	_____	_____	_____	_____
E Major 9 th	_____	<u>G[#]</u>	_____	_____	_____
E Minor 9 th	_____	_____	<u>B</u>	_____	_____
E Dominant 9 th	_____	_____	_____	<u>D</u>	_____
B Major 9 th	_____	_____	_____	_____	<u>C[#]</u>
B Minor 9 th	_____	_____	_____	<u>A</u>	_____
B Dominant 9 th	_____	_____	<u>F[#]</u>	_____	_____
F Major 9 th	_____	_____	_____	_____	<u>G</u>
F Minor 9 th	_____	_____	_____	_____	<u>E^b</u>
F Dominant 9 th	_____	_____	<u>C</u>	_____	_____
B ^b Major 9 th	_____	_____	_____	<u>D</u>	_____
B ^b Minor 9 th	_____	<u>B^b</u>	_____	_____	_____
B ^b Dominant 9 th	_____	_____	<u>D</u>	_____	_____
E ^b Major 9 th	_____	_____	_____	<u>B^b</u>	_____
E ^b Minor 9 th	_____	_____	_____	_____	<u>D^b</u>
E ^b Dominant 9 th	_____	_____	_____	_____	<u>F</u>
A ^b Major 9 th	_____	_____	_____	_____	<u>G</u>
A ^b Minor 9 th	_____	_____	_____	<u>E^b</u>	_____
A ^b Dominant 9 th	_____	<u>C</u>	_____	_____	_____
D ^b Major 9 th	_____	<u>D^b</u>	_____	_____	_____
D ^b Minor 9 th	_____	_____	<u>F^b</u>	_____	_____
D ^b Dominant 9 th	_____	_____	_____	<u>A^b</u>	_____