

Violin Scales and Arpeggios, Grades 1-5

Owain Sutton
www.owainsutton.co.uk

November 8, 2011

Contents

1	Grade 1	5
1.1	D major, one octave	5
1.2	A major, one octave	7
1.3	G major, two octaves	9
1.4	E natural minor, one octave	11
2	Grade 2	13
2.1	G major, two octaves	13
2.2	A major, two octaves	15
2.3	B \flat major, two octaves	17
2.4	C major, one octave	19
2.5	F major, one octave	21
2.6	D harmonic minor scale, one octave	23
2.7	D melodic minor scale, one octave	24
2.8	D natural minor scale, one octave	25
2.9	G harmonic minor scale, one octave	26
2.10	G melodic minor scale, one octave	27
2.11	G natural minor scale, one octave	28
2.12	D & G minor arpeggios, one octave	29
3	Grade 3	30
3.1	B \flat major, two octaves	30
3.2	D major, two octaves	31
3.3	A \flat major, one octave	32
3.4	E \flat major, one octave	33
3.5	E major, one octave	34
3.6	A harmonic minor scale, two octaves	35
3.7	A melodic minor scale, two octaves	36
3.8	A minor arpeggio, two octaves	37
3.9	D harmonic minor scale, two octaves	37
3.10	D melodic minor scale, two octaves	38

3.11	D minor arpeggio, two octaves	39
3.12	Chromatic scale starting on D, one octave	39
4	Grade 4	40
4.1	A \flat major, two octaves	40
4.2	B major, two octaves	41
4.3	C major, two octaves	42
4.4	D major, two octaves	44
4.5	G harmonic minor scale, two octaves	45
4.6	G melodic minor scale, two octaves	46
4.7	B harmonic minor scale, two octaves	47
4.8	B melodic minor scale, two octaves	48
4.9	C harmonic minor scale, two octaves	49
4.10	C melodic minor scale, two octaves	50
4.11	G minor arpeggio, two octaves	51
4.12	B minor arpeggio, two octaves	51
4.13	C minor arpeggio, two octaves	52
4.14	Dominant 7 th in C, one octave	52
4.15	Dominant 7 th in D, one octave	52
4.16	Chromatic scale starting on A, one octave	52
4.17	Chromatic scale starting on E, one octave	53
5	Grade 5	54
5.1	G major, three octaves	54
5.2	A major, three octaves	56
5.3	D \flat major, two octaves	57
5.4	E \flat major, two octaves	59
5.5	F major, two octaves	60
5.6	G harmonic minor scale, three octaves	62
5.7	G melodic minor scale, three octaves	63
5.8	A harmonic minor scale, three octaves	64
5.9	A melodic minor scale, three octaves	66
5.10	B harmonic minor scale, two octaves	68
5.11	B melodic minor scale, two octaves	69
5.12	C \sharp harmonic minor scale, two octaves	70
5.13	C \sharp melodic minor scale, two octaves	71
5.14	E harmonic minor scale, two octaves	72
5.15	E melodic minor scale, two octaves	73
5.16	G minor arpeggio, three octaves	74
5.17	A minor arpeggio, three octaves	74
5.18	B minor arpeggio, two octaves	75

5.19 C# minor arpeggio, two octaves	75
5.20 E minor arpeggio, two octaves	75
5.21 Dominant 7 th in C, two octaves	76
5.22 Dominant 7 th in D, two octaves	76
5.23 Dominant 7 th in B ^b , one octave	77
5.24 Diminished 7 th starting on G, one octave	77
5.25 Diminished 7 th starting on D, one octave	77
5.26 Chromatic scale starting on G, two octaves	77
5.27 Chromatic scale starting on A, two octaves	78
5.28 Chromatic scale starting on B ^b , two octaves	79

One form of minor scales (harmonic, melodic, or at Grade 2 natural) to be played.

Chapter 1

Grade 1

1.1 D major, one octave

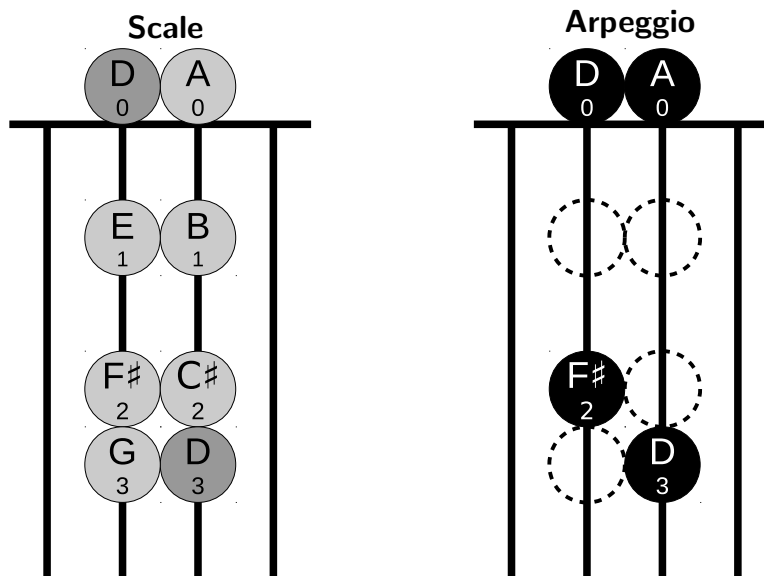

Separate bows



or



Slurred bows



or



Arpeggio



1.2 A major, one octave

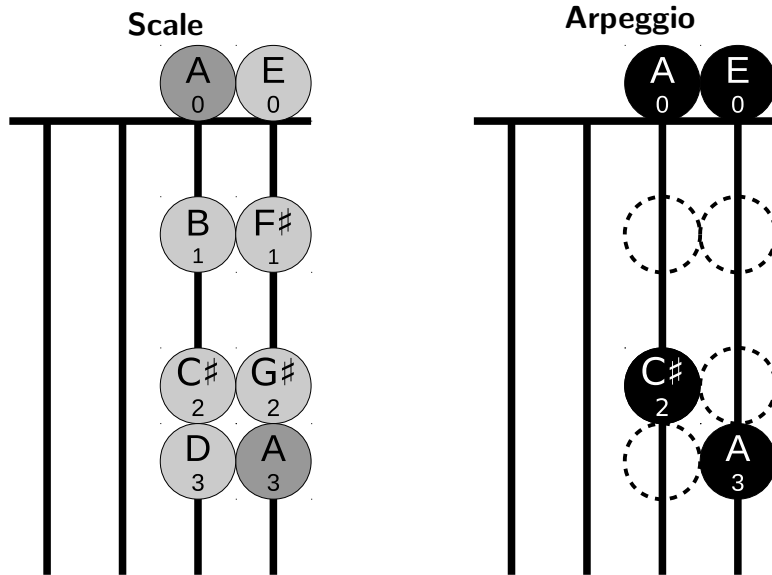

Separate bows

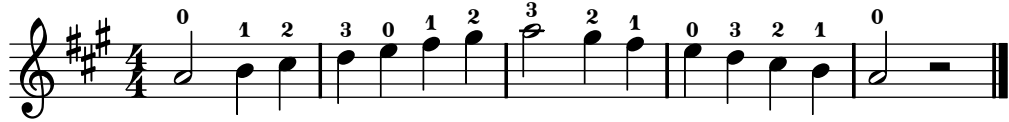

or

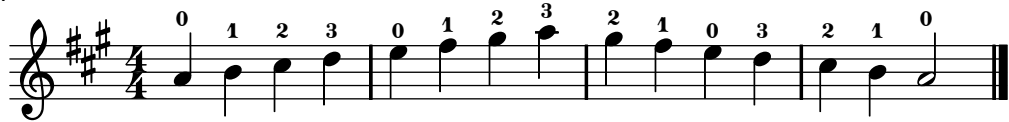

Slurred bows

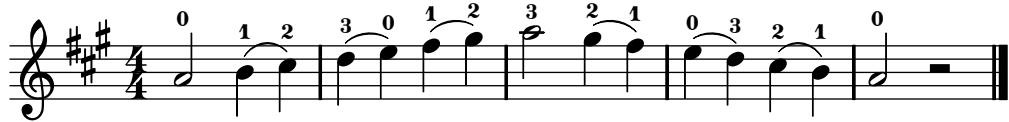

or

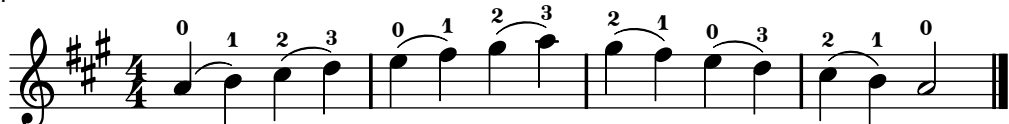

Arpeggio

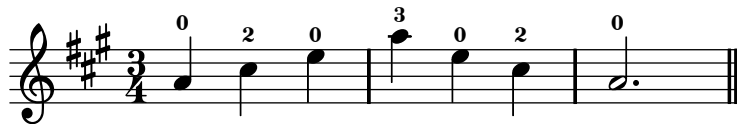

1.3 G major, two octaves

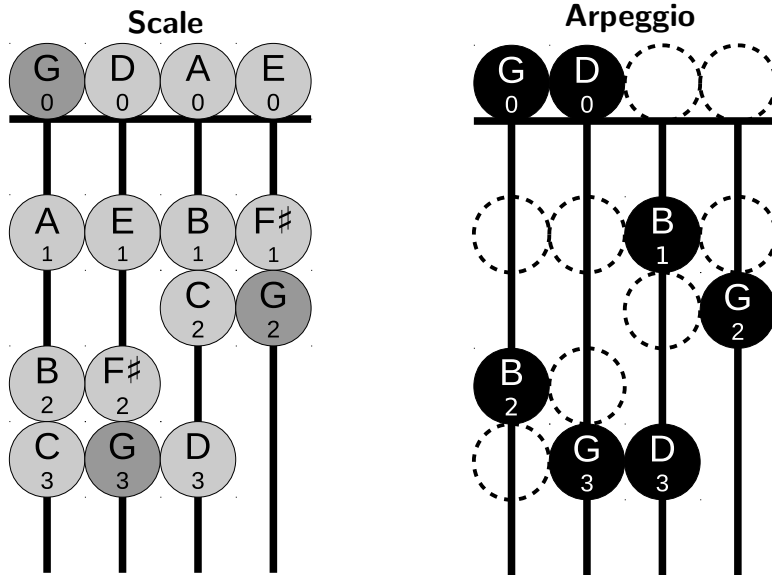

Separate bows

Two staves of music in G major, 4/4 time. The first staff contains the ascending scale with fingerings: 0 1 2 3 0 1 2 3 0 1 2 3 0 1 2 3 0 1 2 1 0. The second staff contains the descending scale with fingerings: 3 2 1 0 3 2 1 0 3 2 1 0.

or

Two staves of music in G major, 4/4 time. The first staff contains the ascending scale with fingerings: 0 1 2 3 0 1 2 3 0 1 2 3 0 1 2 1. The second staff contains the descending scale with fingerings: 0 3 2 1 0 3 2 1 0 3 2 1 0.

Slurred bows

or

Arpeggio

1.4 E natural minor, one octave

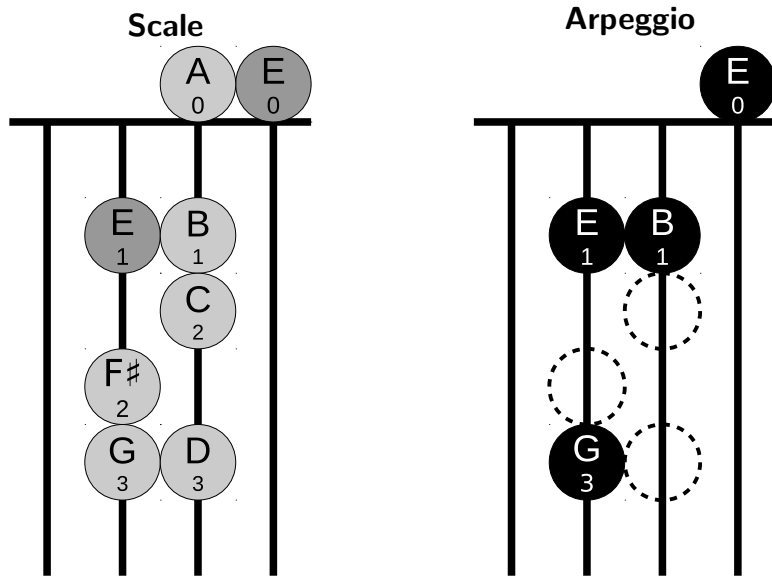

Separate bows



or



Slurred bows

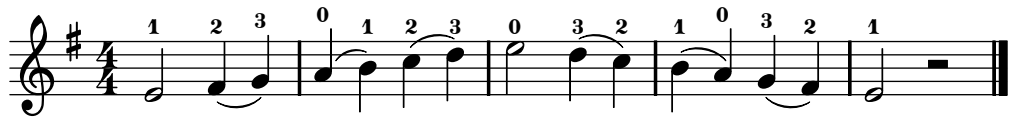

or

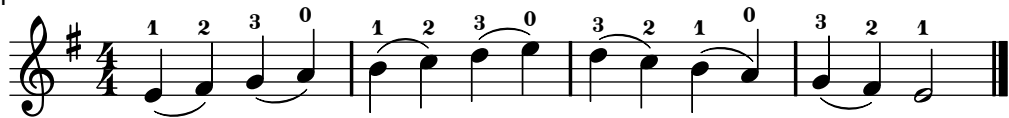

Arpeggio

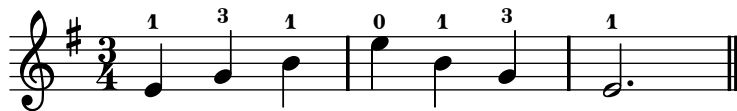

Chapter 2

Grade 2

2.1 G major, two octaves

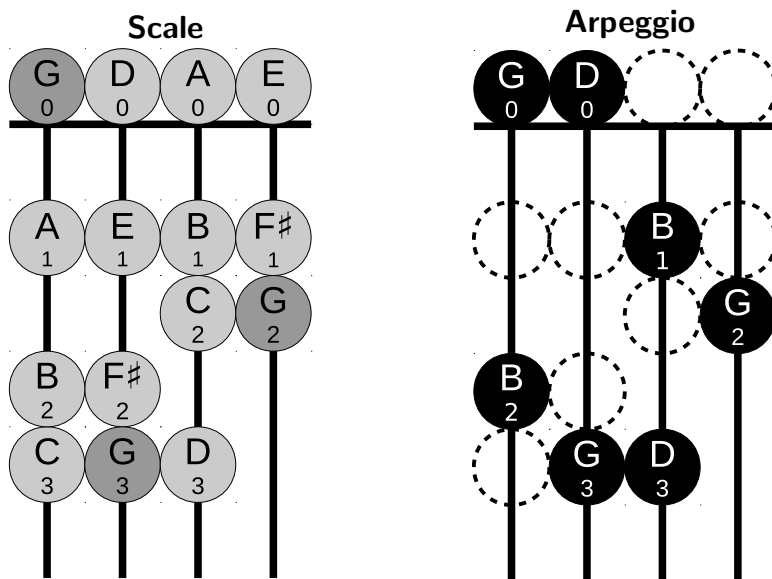

Separate bows

First system of musical notation for 'Separate bows'. It consists of two staves in G major (one sharp) and 4/4 time. The upper staff contains a sequence of eighth notes: G4 (0), A4 (1), B4 (2), C5 (3), G4 (0), A4 (1), B4 (2), C5 (3), G4 (0), A4 (1), B4 (2), C5 (3), G4 (0), A4 (1), B4 (2), C5 (3), G4 (0), A4 (1), B4 (2), C5 (3). The lower staff contains a sequence of eighth notes: C5 (3), B4 (2), A4 (1), G4 (0), C5 (3), B4 (2), A4 (1), G4 (0), C5 (3), B4 (2), A4 (1), G4 (0), C5 (3), B4 (2), A4 (1), G4 (0).

or

Second system of musical notation for 'Separate bows'. It consists of two staves in G major (one sharp) and 4/4 time. The upper staff contains a sequence of eighth notes: G4 (0), A4 (1), B4 (2), C5 (3), G4 (0), A4 (1), B4 (2), C5 (3), G4 (0), A4 (1), B4 (2), C5 (3), G4 (0), A4 (1), B4 (2), C5 (3), G4 (0), A4 (1), B4 (2), C5 (3). The lower staff contains a sequence of eighth notes: C5 (0), B4 (3), A4 (2), G4 (1), C5 (0), B4 (3), A4 (2), G4 (1), C5 (0), B4 (3), A4 (2), G4 (1), C5 (0), B4 (3), A4 (2), G4 (1).

Slurred bows

First system of musical notation for 'Slurred bows'. It consists of two staves in G major (one sharp) and 4/4 time. The upper staff contains a sequence of eighth notes with slurs: G4 (0), A4 (1), B4 (2), C5 (3), G4 (0), A4 (1), B4 (2), C5 (3), G4 (0), A4 (1), B4 (2), C5 (3), G4 (0), A4 (1), B4 (2), C5 (3), G4 (0), A4 (1), B4 (2), C5 (3). The lower staff contains a sequence of eighth notes with slurs: C5 (3), B4 (2), A4 (1), G4 (0), C5 (3), B4 (2), A4 (1), G4 (0), C5 (3), B4 (2), A4 (1), G4 (0), C5 (3), B4 (2), A4 (1), G4 (0).

or

Second system of musical notation for 'Slurred bows'. It consists of two staves in G major (one sharp) and 4/4 time. The upper staff contains a sequence of eighth notes with slurs: G4 (0), A4 (1), B4 (2), C5 (3), G4 (0), A4 (1), B4 (2), C5 (3), G4 (0), A4 (1), B4 (2), C5 (3), G4 (0), A4 (1), B4 (2), C5 (3), G4 (0), A4 (1), B4 (2), C5 (3). The lower staff contains a sequence of eighth notes with slurs: C5 (0), B4 (3), A4 (2), G4 (1), C5 (0), B4 (3), A4 (2), G4 (1), C5 (0), B4 (3), A4 (2), G4 (1), C5 (0), B4 (3), A4 (2), G4 (1).

Arpeggio

Musical notation for 'Arpeggio'. It consists of one staff in G major (one sharp) and 3/4 time. The notes are: G4 (0), B4 (2), D5 (0), G4 (3), A4 (1), B4 (3), G4 (2), A4 (3), B4 (1), G4 (3), D5 (0), B4 (2), G4 (0).

2.2 A major, two octaves

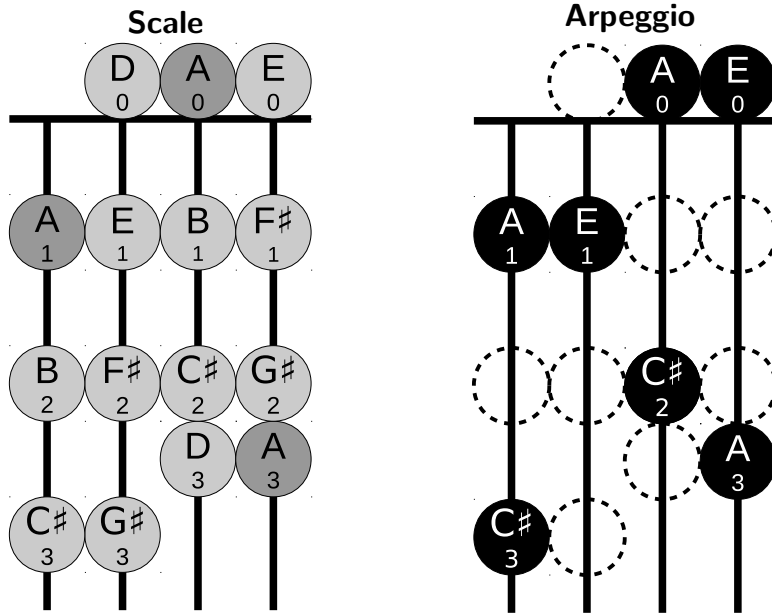

Separate bows

First set of separate bows:

- Staff 1 (Scale): 1 2 3 0 1 2 3 0 1 2 3 0 1 2 3 0 1 2
- Staff 2 (Arpeggio): 3 2 1 0 3 2 1 0 3 2 1 0 3 2 1

or

Second set of separate bows:

- Staff 1 (Scale): 1 2 3 0 1 2 3 0 1 2 3 0 1 2 3 2
- Staff 2 (Arpeggio): 1 0 3 2 1 0 3 2 1 0 3 2 1

Slurred bows

or

Arpeggio

2.3 B \flat major, two octaves

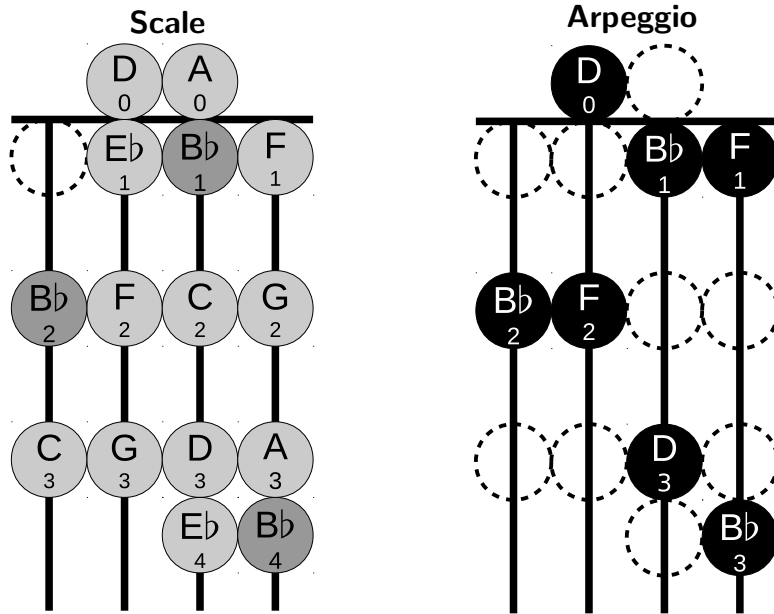

Separate bows

Two staves of musical notation in 4/4 time, B \flat major. The first staff shows the ascending scale with fingerings: 2, 3, 0, 1, 2, 3, 0, 1, 2, 3, 4, 1, 2, 3. The second staff shows the descending scale with fingerings: 4, 3, 2, 1, 4, 3, 2, 1, 0, 3, 2, 1, 0, 3, 2.

or

Two staves of musical notation in 4/4 time, B \flat major, showing an alternative bowing pattern. The first staff shows the ascending scale with fingerings: 2, 3, 0, 1, 2, 3, 0, 1, 2, 3, 4, 1, 2, 3, 4, 3. The second staff shows the descending scale with fingerings: 2, 1, 4, 3, 2, 1, 0, 3, 2, 1, 0, 3, 2.

Slurred bows

Two staves of music in B♭ major, 4/4 time. The first staff contains four measures of music with slurs over groups of notes. Fingerings are indicated by numbers 1-4 above the notes. The second staff contains four measures of music, also with slurs and fingerings. The piece ends with a double bar line.

or

Two staves of music in B♭ major, 4/4 time, serving as an alternative to the first version. The first staff contains four measures of music with slurs and fingerings. The second staff contains four measures of music with slurs and fingerings. The piece ends with a double bar line.

Arpeggio

A single staff of music in B♭ major, 3/4 time. The piece consists of eight measures of music, each containing a single arpeggiated chord. Fingerings are indicated by numbers 1-4 above the notes. The piece ends with a double bar line.

2.4 C major, one octave

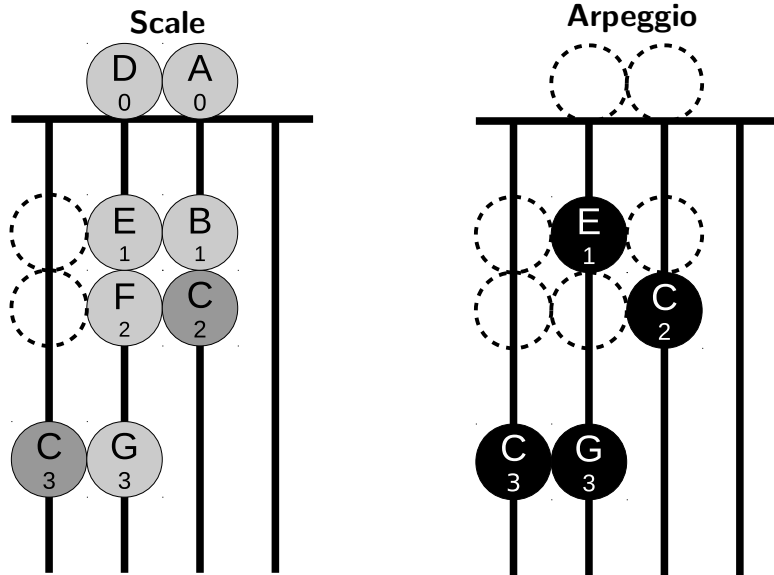

Separate bows



or



Slurred bows



or



Arpeggio



2.5 F major, one octave

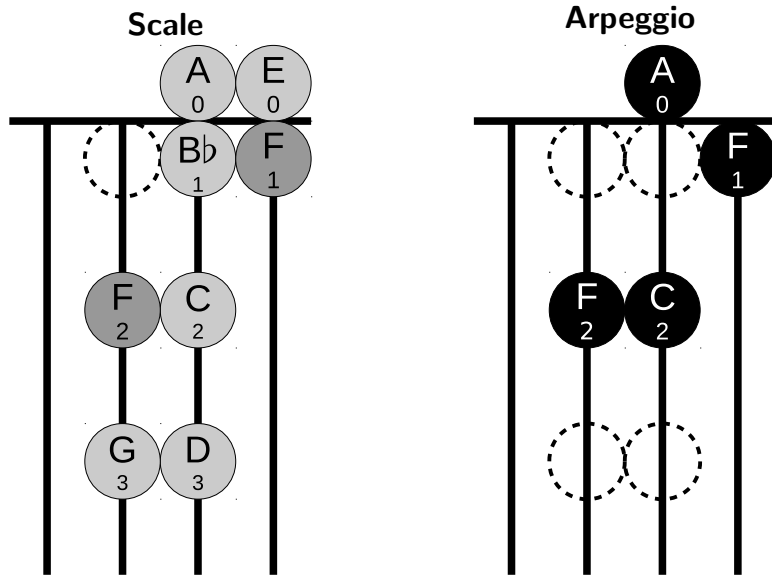

Separate bows

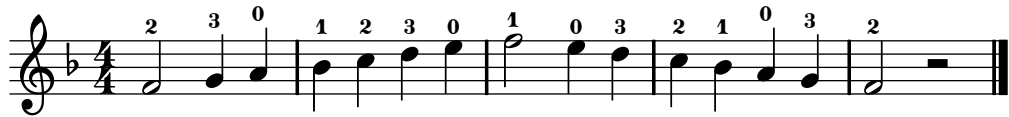

or



Slurred bows

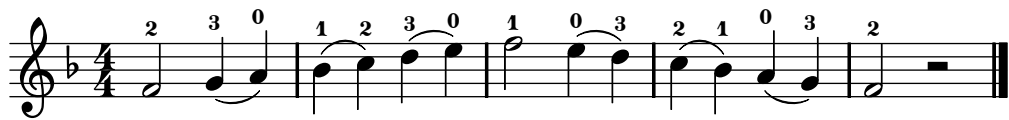

or



Arpeggio

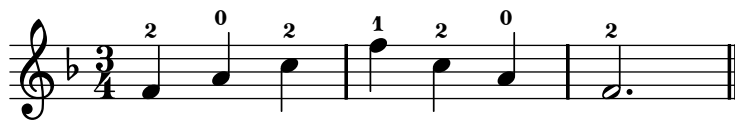

2.6 D harmonic minor scale, one octave

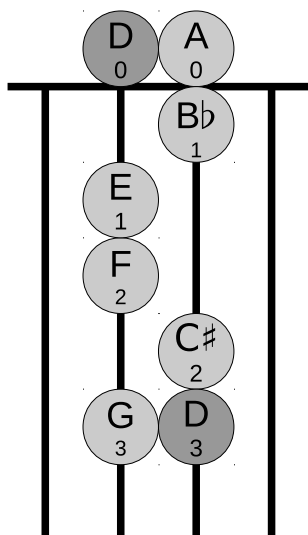

Separate bows



or



Slurred bows



or



2.7 D melodic minor scale, one octave

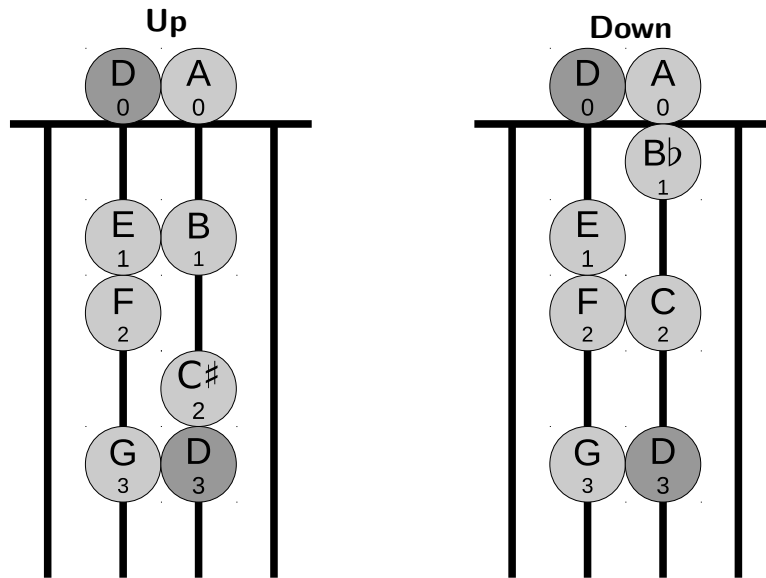

Separate bows

Two musical staves in 4/4 time, showing the D melodic minor scale (one octave) using separate bows. The first staff shows the scale with fingerings: 0 1 2 3 0 1 2 3 2 1 0 3 2 1 0. The second staff is an alternative fingering with fingerings: 0 1 2 3 0 1 2 3 2 1 0 3 2 1 0.

Slurred bows

Two musical staves in 4/4 time, showing the D melodic minor scale (one octave) using slurred bows. The first staff shows the scale with fingerings: 0 1 2 3 0 1 2 3 2 1 0 3 2 1 0. The second staff is an alternative fingering with fingerings: 0 1 2 3 0 1 2 3 2 1 0 3 2 1 0.

2.8 D natural minor scale, one octave

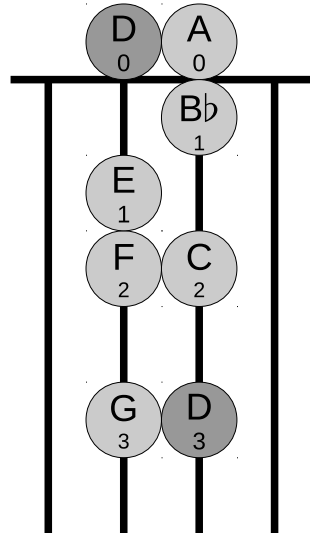

Separate bows



or



Slurred bows



or



2.9 G harmonic minor scale, one octave

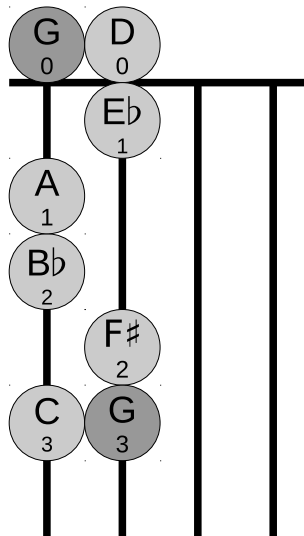

Separate bows

or

Slurred bows

or

2.10 G melodic minor scale, one octave

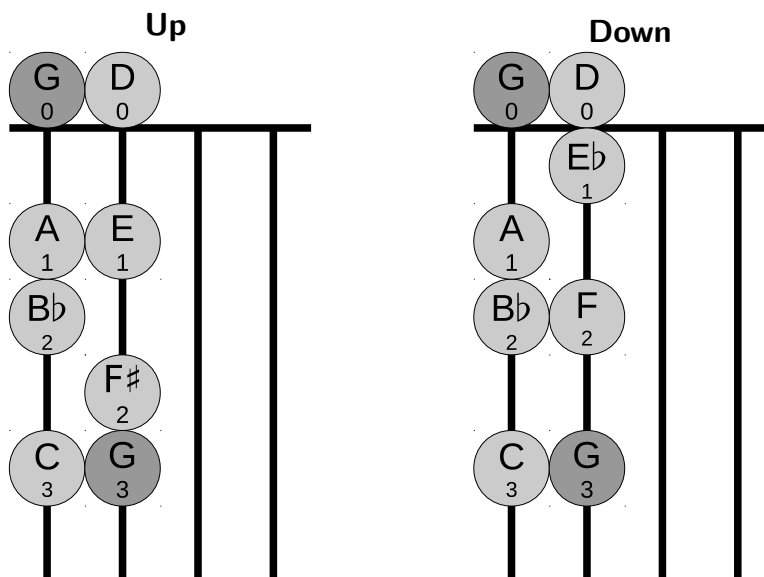

Separate bows



or



Slurred bows

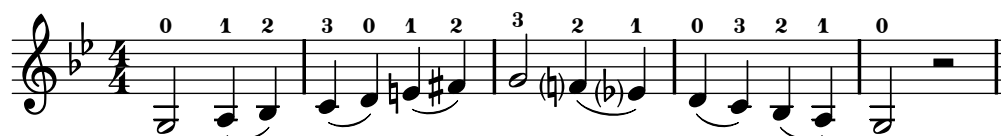

or

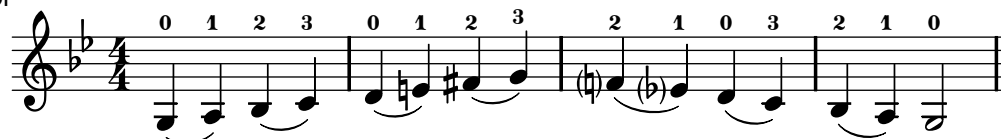

2.11 G natural minor scale, one octave

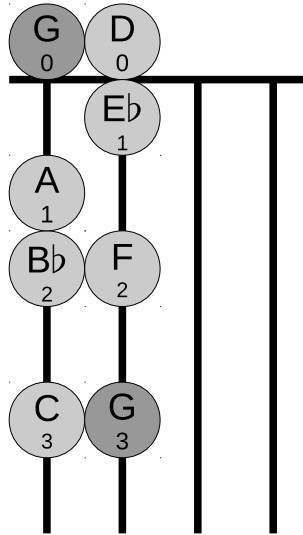

Separate bows



or



Slurred bows

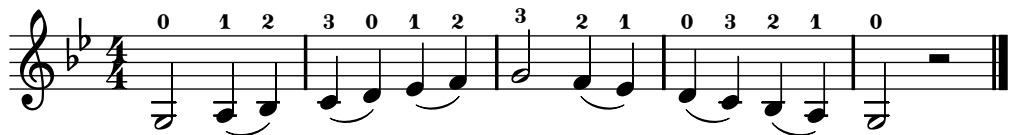

or

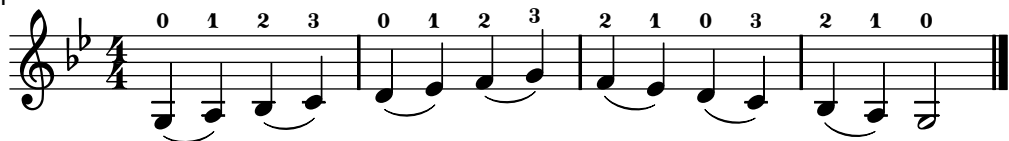

2.12 D & G minor arpeggios, one octave

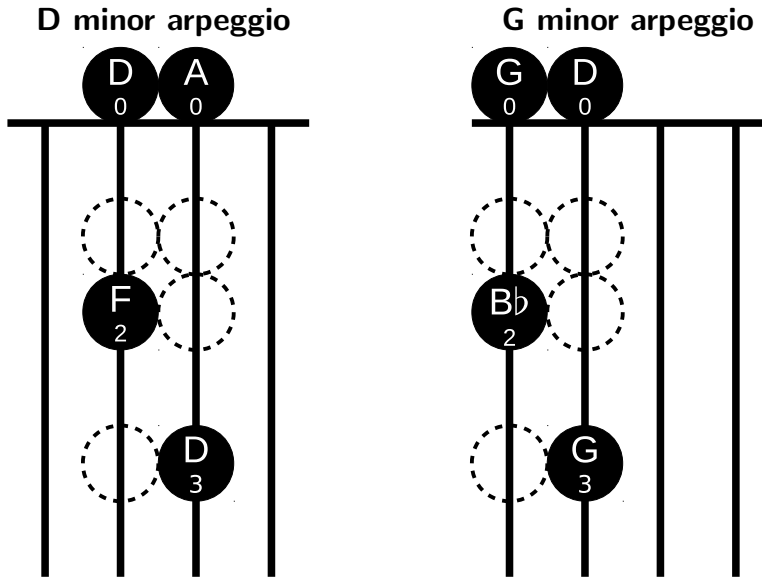

D minor arpeggio

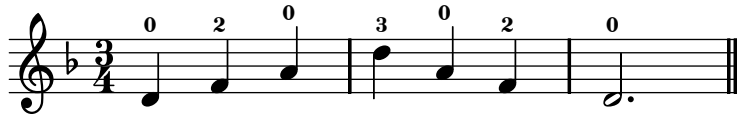

G minor arpeggio

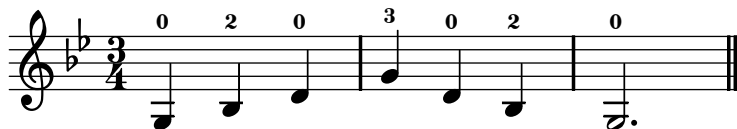

Chapter 3

Grade 3

3.1 B \flat major, two octaves

Separate bows

Musical notation for 'Separate bows' in B \flat major, 4/4 time. The first staff starts with a 2nd finger on the first note, followed by a 0th finger on the second note, and a 4th finger on the third note. The second staff starts with a 4th finger on the first note, followed by a 0th finger on the second note, and a 2nd finger on the third note.

or

Musical notation for 'Separate bows' in B \flat major, 4/4 time. The first staff starts with a 2nd finger on the first note, followed by a 0th finger on the second note, and a 4th finger on the third note. The second staff starts with a 4th finger on the first note, followed by a 0th finger on the second note, and a 2nd finger on the third note.

Slurred bows

Musical notation for 'Slurred bows' in B \flat major, 4/4 time. The first staff starts with a 2nd finger on the first note, followed by a 0th finger on the second note, and a 4th finger on the third note. The second staff starts with a 4th finger on the first note, followed by a 0th finger on the second note, and a 2nd finger on the third note.

or

Musical notation for D major, two octaves, slurred bows. The piece is in 4/4 time and B-flat major. The first staff contains four measures of music with fingerings 2, 0, 0, 4, 4. The second staff contains four measures with fingerings 4, 0, 0. Slurs are placed over the notes in each measure.

Arpeggio, separate bows

Musical notation for D major, two octaves, arpeggio, separate bows. The piece is in 3/4 time and B-flat major. The notation shows a sequence of notes with fingerings: 2, 0, 2, 1, 3, 1, 4, 1, 3, 1, 2, 0, 2.

Arpeggio, slurred bows

Musical notation for D major, two octaves, arpeggio, slurred bows. The piece is in 3/4 time and B-flat major. The notation shows a sequence of notes with fingerings: 2, 0, 2, 1, 3, 1, 4, 1, 3, 1, 2, 0, 2. Slurs are placed over the notes in each measure.

3.2 D major, two octaves

Separate bows

Musical notation for D major, two octaves, separate bows. The piece is in 4/4 time and D major. The first staff contains four measures with fingerings 0, 0, 2, 1, 4, 1. The second staff contains four measures with fingerings 4, 1, 4, 1, 2, 0, 0.

or

Musical notation for D major, two octaves, separate bows, alternative fingering. The piece is in 4/4 time and D major. The first staff contains four measures with fingerings 0, 0, 2, 1, 4, 1. The second staff contains four measures with fingerings 1, 4, 1, 2, 0, 0.

Slurred bows

Two staves of music in A \flat major, 4/4 time. The first staff contains two measures: the first measure has a quarter note (0), an eighth note (0), and a quarter note (2); the second measure has a quarter note (1), an eighth note (4), and a quarter note (1). The second staff contains two measures: the first measure has a quarter note (4), an eighth note (1), and a quarter note (4); the second measure has a quarter note (1), an eighth note (2), and a quarter note (0). The piece ends with a double bar line.

or

Two staves of music in A \flat major, 4/4 time. The first staff contains two measures: the first measure has a quarter note (0), an eighth note (0), and a quarter note (2); the second measure has a quarter note (1), an eighth note (4), and a quarter note (1). The second staff contains two measures: the first measure has a quarter note (1), an eighth note (4), and a quarter note (1); the second measure has a quarter note (1), an eighth note (2), and a quarter note (0). The piece ends with a double bar line.

Arpeggio, separate bows

One staff of music in A \flat major, 3/4 time. The notes are: quarter note (0), quarter note (2), quarter note (0), quarter note (1), quarter note (3), quarter note (1), quarter note (4), quarter note (1), quarter note (3), quarter note (1), quarter note (0), quarter note (2), quarter note (0). The piece ends with a double bar line.

Arpeggio, slurred bows

One staff of music in A \flat major, 3/4 time. The notes are: quarter note (0), quarter note (2), quarter note (0), quarter note (1), quarter note (3), quarter note (1), quarter note (4), quarter note (1), quarter note (3), quarter note (1), quarter note (0), quarter note (2), quarter note (0). The piece ends with a double bar line.

3.3 A \flat major, one octave

Scale, separate bows

One staff of music in A \flat major, 4/4 time. The notes are: quarter note (1), quarter note (4), quarter note (1), quarter note (4), quarter note (1), quarter note (4), quarter note (1), quarter note (4), quarter note (1), quarter note (4), quarter note (1), quarter note (4), quarter note (1), quarter note (4), quarter note (1), quarter note (4). The piece ends with a double bar line.

or

**Scale, slurred bows**

or

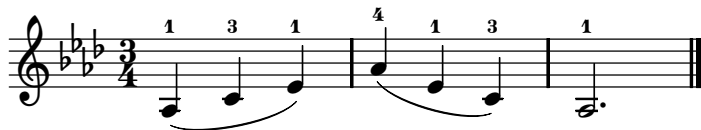
**Arpeggio, separate bows****Arpeggio, slurred bows****3.4 E \flat major, one octave****Scale, separate bows**

or



Scale, slurred bows

Two musical staves in treble clef, key signature of two flats (B-flat, E-flat), and 4/4 time signature. The first staff shows an ascending scale with slurs over groups of notes and fingerings: 1, 4, 1, 4, 1, 4, 1. The second staff shows a descending scale with slurs and fingerings: 4, 1, 4, 1, 4, 1, 4.

Arpeggio, separate bows

Musical staff in treble clef, key signature of two flats, and 3/4 time signature. The notes are E, G, B, A, G, E. Fingerings are: 1, 3, 1, 4, 1, 3, 1.

Arpeggio, slurred bows

Musical staff in treble clef, key signature of two flats, and 3/4 time signature. The notes are E, G, B, A, G, E. Fingerings are: 1, 3, 1, 4, 1, 3, 1. Slurs are placed over the first three notes and the last three notes.

3.5 E major, one octave

Scale, separate bows

Two musical staves in treble clef, key signature of three sharps (F#, C#, G#), and 4/4 time signature. The first staff shows an ascending scale with separate bows and fingerings: 1, 4, 4, 4, 1. The second staff shows a descending scale with separate bows and fingerings: 4, 4, 4, 1.

Scale, slurred bows

Two musical staves in treble clef, key signature of three sharps, and 4/4 time signature. The first staff shows an ascending scale with slurs and fingerings: 1, 4, 4, 4, 1. The second staff shows a descending scale with slurs and fingerings: 4, 4, 4, 1.

Arpeggio, separate bows



Arpeggio, slurred bows



3.6 A harmonic minor scale, two octaves

Separate bows

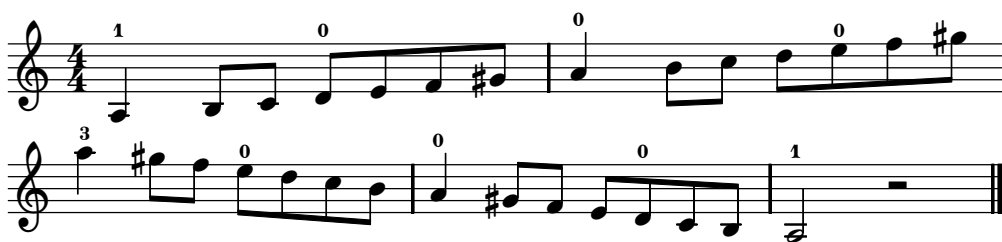

or



Slurred bows



or



3.7 A melodic minor scale, two octaves

Separate bows



or



Slurred bows



or

Musical notation for A minor arpeggio, two octaves. The first staff shows the ascending arpeggio with fingerings 1, 0, 0, 0, 0, 3. The second staff shows the descending arpeggio with fingerings 0, 0, 0, 0, 0, 0.

3.8 A minor arpeggio, two octaves

Separate bows

Musical notation for A minor arpeggio, two octaves, separate bows. The notation shows the ascending and descending arpeggios with fingerings 1, 3, 1, 0, 2, 0, 3, 0, 2, 0, 1, 3, 1.

Slurred bows

Musical notation for A minor arpeggio, two octaves, slurred bows. The notation shows the ascending and descending arpeggios with fingerings 1, 3, 1, 0, 2, 0, 3, 0, 2, 0, 1, 3, 1.

3.9 D harmonic minor scale, two octaves

Separate bows

Musical notation for D harmonic minor scale, two octaves, separate bows. The notation shows the ascending and descending scales with fingerings 0, 0, 2, 1, 4, 1, 4, 1, 4, 1, 1, 2, 0, 0.

or

Musical notation for D harmonic minor scale, two octaves, or. The notation shows the ascending and descending scales with fingerings 0, 0, 2, 1, 4, 1, 4, 1, 4, 1, 1, 2, 0, 0.

Slurred bows

Two staves of music in 4/4 time, key of D minor. The first staff contains the first four measures of the scale, and the second staff contains the last four measures. Slurs are placed over groups of notes to indicate they should be played with a single bow stroke. Fingering numbers (0, 1, 2, 4) are written above the notes.

or

Two staves of music in 4/4 time, key of D minor, providing an alternative fingering for the slurred bow technique. The notes and slurs are identical to the first system, but the fingering numbers (0, 1, 2, 4) are distributed differently across the notes.

3.10 D melodic minor scale, two octaves

Separate bows

Two staves of music in 4/4 time, key of D minor. The first staff contains the first four measures, and the second staff contains the last four measures. Each note is marked with a separate bowing symbol (a vertical line with a flag) and a fingering number (0, 1, 2, 4), indicating that each note should be played with a separate bow stroke.

or

Two staves of music in 4/4 time, key of D minor, providing an alternative bowing and fingering for the separate bows technique. The notes and bowing symbols are identical to the first system, but the fingering numbers (0, 1, 2, 4) are distributed differently.

Slurred bows

or

3.11 D minor arpeggio, two octaves**Separate bows**
Slurred bows
3.12 Chromatic scale starting on D, one octave

Chapter 4

Grade 4

4.1 A \flat major, two octaves

Scale, separate bows

Musical notation for the A \flat major scale, two octaves, using separate bows. The scale is written in treble clef with a key signature of two flats (B \flat and E \flat) and a 4/4 time signature. The first line shows the ascending scale with fingerings: 1, 4, 1, 4, 1, 4, 1, 4, 1, 4, 1, 4. The second line shows the descending scale with fingerings: 3, 1, 4, 1, 4, 1, 4, 1, 4, 1, 4, 1. The piece ends with a double bar line.

or

Musical notation for the A \flat major scale, two octaves, using slurred bows. The scale is written in treble clef with a key signature of two flats (B \flat and E \flat) and a 4/4 time signature. The first line shows the ascending scale with fingerings: 1, 4, 1, 4, 1, 4, 1, 4, 1, 4, 3. The second line shows the descending scale with fingerings: 1, 4, 1, 4, 1, 4, 1, 4, 1. The piece ends with a double bar line.

Scale, slurred bows

Musical notation for the A \flat major scale, two octaves, using slurred bows. The scale is written in treble clef with a key signature of two flats (B \flat and E \flat) and a 4/4 time signature. The first line shows the ascending scale with fingerings: 1, 4, 1, 4, 1, 4, 1, 4, 1, 4, 1. The second line shows the descending scale with fingerings: 3, 1, 4, 1, 4, 1, 4, 1, 4, 1, 4, 1. The piece ends with a double bar line.

or

Arpeggio, separate bows
Arpeggio, slurred bows
4.2 B major, two octaves**Separate bows**

or

Slurred bows

Two staves of music in C major, 4/4 time. The first staff contains two measures of music with slurs over groups of notes and fingerings (2, 4, 1, 4, 1, 4, 1) indicated above. The second staff contains two measures of music with slurs and fingerings (4, 1, 4, 1, 4, 1, 2) indicated above.

or

Two staves of music in C major, 4/4 time. The first staff contains two measures of music with slurs and fingerings (2, 4, 1, 4, 1, 4, 1) indicated above. The second staff contains two measures of music with slurs and fingerings (1, 4, 1, 4, 1, 4) indicated above.

Arpeggio, separate bows

One staff of music in C major, 6/8 time. The notation shows an arpeggiated pattern with slurs and fingerings (2, 4, 2, 1, 3, 1, 4, 1, 3, 1, 2, 4, 2) indicated above.

Arpeggio, slurred bows

One staff of music in C major, 6/8 time. The notation shows an arpeggiated pattern with slurs and fingerings (2, 4, 2, 1, 3, 1, 4, 1, 3, 1, 2, 4, 2) indicated above.

4.3 C major, two octaves

Separate bows

Two staves of music in C major, 4/4 time. The first staff contains two measures of music with separate bows and fingerings (2, 4, 1, 4, 1, 4, 1) indicated above. The second staff contains two measures of music with separate bows and fingerings (4, 1, 4, 1, 4, 1, 2) indicated above.

or

Musical notation for a C major scale exercise in 4/4 time, two octaves. The notation consists of two staves. The first staff shows the ascending scale with fingerings: 2, 4, 1, 4, 1, 4, 1, 4, 1, 4, 1, 4, 1, 4, 1. The second staff shows the descending scale with fingerings: 1, 4, 1, 4, 1, 4, 1, 4, 2.

Slurred bows

Musical notation for a C major scale exercise in 4/4 time, two octaves, with slurred bows. The notation consists of two staves. The first staff shows the ascending scale with slurred bows and fingerings: 2, 4, 1, 4, 1, 4, 1, 4, 1, 4, 1, 4, 1, 4, 1. The second staff shows the descending scale with slurred bows and fingerings: 4, 1, 4, 1, 4, 1, 4, 2.

or

Musical notation for a C major scale exercise in 4/4 time, two octaves, with slurred bows. The notation consists of two staves. The first staff shows the ascending scale with slurred bows and fingerings: 2, 4, 1, 4, 1, 4, 1, 4, 1, 4, 1, 4, 1, 4, 1. The second staff shows the descending scale with slurred bows and fingerings: 1, 4, 1, 4, 1, 4, 2.

Arpeggio, separate bows

Musical notation for a C major arpeggio exercise in 6/8 time. The notation consists of one staff. The arpeggio is played in two octaves, with separate bows for each note. Fingerings are: 2, 4, 2, 1, 3, 1, 4, 1, 3, 1, 2, 4, 2.

Arpeggio, slurred bows

Musical notation for a C major arpeggio exercise in 6/8 time, with slurred bows. The notation consists of one staff. The arpeggio is played in two octaves, with slurred bows for each note. Fingerings are: 2, 4, 2, 1, 3, 1, 4, 1, 3, 1, 2, 4, 2.

4.4 D major, two octaves

Separate bows

Musical notation for the first exercise, 'Separate bows'. It consists of two staves in D major (two sharps) and 4/4 time. The first staff contains two measures: the first measure has notes D4, E4, F#4, G4 with fingerings 2, 4, 1, 4; the second measure has notes A4, B4, C5, D5 with fingerings 1, 4, 1, 4. The second staff contains three measures: the first measure has notes E4, F#4, G4, A4 with fingerings 4, 1, 4, 1; the second measure has notes B4, C5, D5, E5 with fingerings 1, 4, 1, 4; the third measure has notes F#5, G5, A5, B5 with fingerings 1, 4, 2.

or

Musical notation for the second exercise, 'Separate bows'. It consists of two staves in D major (two sharps) and 4/4 time. The first staff contains two measures: the first measure has notes D4, E4, F#4, G4 with fingerings 2, 4, 1, 4; the second measure has notes A4, B4, C5, D5 with fingerings 4, 1, 4, 1. The second staff contains three measures: the first measure has notes E4, F#4, G4, A4 with fingerings 1, 4, 1, 4; the second measure has notes B4, C5, D5, E5 with fingerings 1, 4, 1, 4; the third measure has notes F#5, G5, A5, B5 with fingerings 1, 4, 2.

Slurred bows

Musical notation for the first exercise, 'Slurred bows'. It consists of two staves in D major (two sharps) and 4/4 time. The first staff contains two measures: the first measure has notes D4, E4, F#4, G4 with fingerings 2, 4, 1, 4 and slurs over each pair; the second measure has notes A4, B4, C5, D5 with fingerings 1, 4, 1, 4 and slurs over each pair. The second staff contains three measures: the first measure has notes E4, F#4, G4, A4 with fingerings 4, 1, 4, 1 and slurs over each pair; the second measure has notes B4, C5, D5, E5 with fingerings 1, 4, 1, 4 and slurs over each pair; the third measure has notes F#5, G5, A5, B5 with fingerings 1, 4, 2 and slurs over each pair.

or

Musical notation for the second exercise, 'Slurred bows'. It consists of two staves in D major (two sharps) and 4/4 time. The first staff contains two measures: the first measure has notes D4, E4, F#4, G4 with fingerings 2, 4, 1, 4 and slurs over each pair; the second measure has notes A4, B4, C5, D5 with fingerings 4, 1, 4, 1 and slurs over each pair. The second staff contains three measures: the first measure has notes E4, F#4, G4, A4 with fingerings 1, 4, 1, 4 and slurs over each pair; the second measure has notes B4, C5, D5, E5 with fingerings 1, 4, 1, 4 and slurs over each pair; the third measure has notes F#5, G5, A5, B5 with fingerings 1, 4, 2 and slurs over each pair.

Arpeggio, separate bows

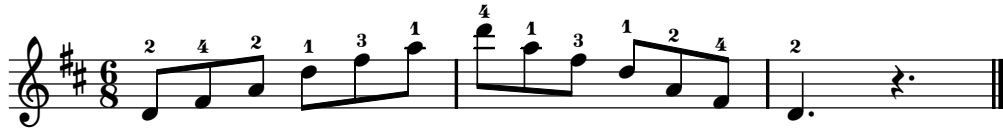

Arpeggio, slurred bows



4.5 G harmonic minor scale, two octaves

Separate bows



or



Slurred bows



or

Musical notation for the G melodic minor scale, two octaves, using slurred bows. The notation is in G minor (one flat) and 4/4 time. The first staff shows the ascending scale with fingerings: 0, 0, 0, 4, 1, 2, 1. The second staff shows the descending scale with fingerings: 4, 0, 0, 0.

4.6 G melodic minor scale, two octaves

Separate bows

Musical notation for the G melodic minor scale, two octaves, using separate bows. The notation is in G minor (one flat) and 4/4 time. The first staff shows the ascending scale with fingerings: 0, 0, 0, 0, 1. The second staff shows the descending scale with fingerings: 2, 1, 4, 0, 0, 0.

or

Musical notation for the G melodic minor scale, two octaves, using separate bows, alternative fingering. The notation is in G minor (one flat) and 4/4 time. The first staff shows the ascending scale with fingerings: 0, 0, 0, 0, 1, 2, 1. The second staff shows the descending scale with fingerings: 4, 0, 0, 0.

Slurred bows

Musical notation for the G melodic minor scale, two octaves, using slurred bows. The notation is in G minor (one flat) and 4/4 time. The first staff shows the ascending scale with fingerings: 0, 0, 0, 0, 1. The second staff shows the descending scale with fingerings: 2, 1, 4, 0, 0, 0.

or

Musical notation for the B harmonic minor scale, two octaves, in 4/4 time. The scale is written in two staves. The first staff shows the ascending scale with fingerings: 0, 0, 0, 0, 1, 2, 1. The second staff shows the descending scale with fingerings: 4, 0, 0, 0.

4.7 B harmonic minor scale, two octaves

Separate bows

Musical notation for the B harmonic minor scale, two octaves, in 4/4 time, using separate bows. The scale is written in two staves. The first staff shows the ascending scale with fingerings: 2, 4, 1, 4, 1, 4, 1. The second staff shows the descending scale with fingerings: 4, 1, 4, 1, 4, 1, 2.

or

Musical notation for the B harmonic minor scale, two octaves, in 4/4 time, using separate bows. The scale is written in two staves. The first staff shows the ascending scale with fingerings: 2, 4, 1, 4, 1, 4, 1. The second staff shows the descending scale with fingerings: 1, 4, 1, 4, 1, 4, 2.

Slurred bows

Musical notation for the B harmonic minor scale, two octaves, in 4/4 time, using slurred bows. The scale is written in two staves. The first staff shows the ascending scale with fingerings: 2, 4, 1, 4, 1, 4, 1. The second staff shows the descending scale with fingerings: 4, 1, 4, 1, 4, 1, 2.

or

Musical notation for the B melodic minor scale, two octaves, with separate bows. The notation is in treble clef, key of B major (two sharps), and 4/4 time. The scale is written across two staves. The first staff contains the first two octaves of the scale, and the second staff contains the last two octaves. Fingerings are indicated by numbers 1, 2, and 4 above the notes. Slurs are placed over groups of notes to indicate separate bows.

4.8 B melodic minor scale, two octaves

Separate bows

Musical notation for the B melodic minor scale, two octaves, with separate bows. The notation is in treble clef, key of B major (two sharps), and 4/4 time. The scale is written across two staves. The first staff contains the first two octaves of the scale, and the second staff contains the last two octaves. Fingerings are indicated by numbers 1, 2, and 4 above the notes. Slurs are placed over groups of notes to indicate separate bows.

or

Alternative musical notation for the B melodic minor scale, two octaves, with separate bows. The notation is in treble clef, key of B major (two sharps), and 4/4 time. The scale is written across two staves. The first staff contains the first two octaves of the scale, and the second staff contains the last two octaves. Fingerings are indicated by numbers 1, 2, and 4 above the notes. Slurs are placed over groups of notes to indicate separate bows.

Slurred bows

Musical notation for the B melodic minor scale, two octaves, with slurred bows. The notation is in treble clef, key of B major (two sharps), and 4/4 time. The scale is written across two staves. The first staff contains the first two octaves of the scale, and the second staff contains the last two octaves. Fingerings are indicated by numbers 1, 2, and 4 above the notes. Slurs are placed over groups of notes to indicate slurred bows.

or

4.9 C harmonic minor scale, two octaves

Separate bows

or

Slurred bows

or

Musical notation for the C melodic minor scale, two octaves, using slurred bows. The notation is in 4/4 time and C minor. The first staff shows the ascending scale with fingerings: 2, 4, 1, 4, 1, 4, 1, 4, 1. The second staff shows the descending scale with fingerings: 1, 4, 1, 4, 1, 4, 2. The notes are slurred across the entire scale.

4.10 C melodic minor scale, two octaves

Separate bows

Musical notation for the C melodic minor scale, two octaves, using separate bows. The notation is in 4/4 time and C minor. The first staff shows the ascending scale with fingerings: 2, 4, 1, 4, 1, 4, 1, 4, 1. The second staff shows the descending scale with fingerings: 4, (b), (b), 1, 4, 1, 4, 1, 4, 2. The notes are not slurred.

or

Musical notation for the C melodic minor scale, two octaves, using separate bows, alternative fingering. The notation is in 4/4 time and C minor. The first staff shows the ascending scale with fingerings: 2, 4, 1, 4, 1, 4, 1, 4, 1. The second staff shows the descending scale with fingerings: (b), 1, 4, 1, 4, 1, 4, 2. The notes are not slurred.

Slurred bows

Musical notation for the C melodic minor scale, two octaves, using slurred bows. The notation is in 4/4 time and C minor. The first staff shows the ascending scale with fingerings: 2, 4, 1, 4, 1, 4, 1, 4, 1. The second staff shows the descending scale with fingerings: 4, (b), (b), 1, 4, 1, 4, 2. The notes are slurred across the entire scale.

or

4.11 G minor arpeggio, two octaves

Separate bows

Slurred bows

4.12 B minor arpeggio, two octaves

Separate bows

Slurred bows

4.13 C minor arpeggio, two octaves

Separate bows



Slurred bows

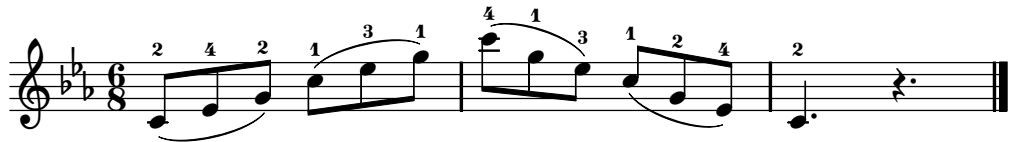

4.14 Dominant 7th in C, one octave

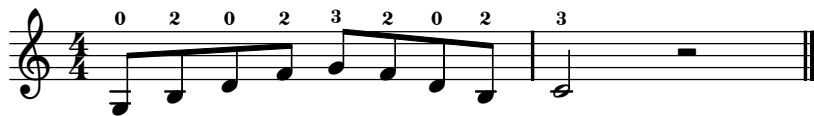

4.15 Dominant 7th in D, one octave



4.16 Chromatic scale starting on A, one octave

Separate bows

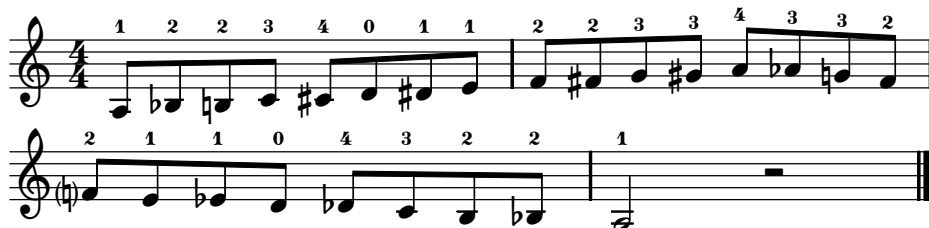

Slurred bows

Musical notation for a chromatic scale starting on E, one octave, using slurred bows. The piece is in 4/4 time and consists of two staves. The upper staff is in treble clef and the lower staff is in bass clef. The key signature has one sharp (F#). The notation includes fingerings (1-4) and slurs over the notes. The upper staff contains the ascending and descending chromatic scale, while the lower staff contains the corresponding bass clef notes.

4.17 Chromatic scale starting on E, one octave

Separate bows

Musical notation for a chromatic scale starting on E, one octave, using separate bows. The piece is in 4/4 time and consists of two staves. The upper staff is in treble clef and the lower staff is in bass clef. The key signature has one sharp (F#). The notation includes fingerings (1-4) and separate bow strokes for each note. The upper staff contains the ascending and descending chromatic scale, while the lower staff contains the corresponding bass clef notes.

Slurred bows

Musical notation for a chromatic scale starting on E, one octave, using slurred bows. The piece is in 4/4 time and consists of two staves. The upper staff is in treble clef and the lower staff is in bass clef. The key signature has one sharp (F#). The notation includes fingerings (1-4) and slurs over the notes. The upper staff contains the ascending and descending chromatic scale, while the lower staff contains the corresponding bass clef notes.

Chapter 5

Grade 5

5.1 G major, three octaves

Scale, separate bows

Musical notation for the G major scale, three octaves, first version. The notation is in treble clef with a key signature of one sharp (F#) and a 4/4 time signature. The scale is written across two staves. The first staff contains the ascending scale: G4 (0), A4 (0), B4 (0), C5 (2), D5 (1), E5 (4), F#5 (1), G5 (2), A5 (1), B5 (4), C6 (4), D6 (4), E6 (4), F#6 (4), G6 (4). The second staff contains the descending scale: F#6 (4), E6 (4), D6 (4), C6 (1), B5 (2), A5 (1), G5 (4), F#5 (0), E5 (0), D5 (0), C5 (0), B4 (0), A4 (0), G4 (0).

or

Musical notation for the G major scale, three octaves, second version. The notation is in treble clef with a key signature of one sharp (F#) and a 4/4 time signature. The scale is written across two staves. The first staff contains the ascending scale: G4 (0), A4 (0), B4 (0), C5 (2), D5 (1), E5 (4), F#5 (1), G5 (2), A5 (1), B5 (4), C6 (4), D6 (4), E6 (4), F#6 (4), G6 (4). The second staff contains the descending scale: F#6 (4), E6 (4), D6 (4), C6 (1), B5 (2), A5 (1), G5 (4), F#5 (0), E5 (0), D5 (0), C5 (0), B4 (0), A4 (0), G4 (0).

Scale, slurred bows

Musical notation for a G major scale with slurred bows, first version. The scale is written in treble clef, G major (one sharp), and 4/4 time. It consists of two staves. The first staff contains the first two measures, and the second staff contains the last two measures. Fingerings (0, 2, 1, 4, 1, 2, 1, 4) and slurs are indicated throughout.

or

Musical notation for a G major scale with slurred bows, second version. The scale is written in treble clef, G major (one sharp), and 4/4 time. It consists of two staves. The first staff contains the first two measures, and the second staff contains the last two measures. Fingerings (0, 2, 1, 4, 1, 2, 1, 4) and slurs are indicated throughout.

Arpeggio, separate bows

Musical notation for a G major arpeggio with separate bows, written in treble clef, G major (one sharp), and 3/8 time. The notation shows the sequence of notes G-A-B-A-G-F-E-D with fingerings (0, 2, 0, 1, 3, 1, 1, 3, 1, 4, 1, 3, 1, 1, 3, 1, 0, 2, 0) and a final whole note G.

Arpeggio, slurred bows

Musical notation for a G major arpeggio with slurred bows, written in treble clef, G major (one sharp), and 3/8 time. The notation shows the sequence of notes G-A-B-A-G-F-E-D with fingerings (0, 2, 0, 1, 3, 1, 1, 3, 1, 4, 1, 3, 1, 1, 3, 1, 0, 2, 0) and slurs over the notes.

5.2 A major, three octaves

Scale, separate bows

Musical notation for the A major scale, three octaves, using separate bows. The notation is in treble clef with a key signature of three sharps (F#, C#, G#) and a 4/4 time signature. The scale is written across two staves. The first staff contains the first two octaves, and the second staff contains the third octave. Fingerings are indicated by numbers 1, 2, 3, 4, and 0 (open string). The bowing is indicated by the phrasing of the notes, with separate bows for each note or group of notes.

or

Alternative musical notation for the A major scale, three octaves, using separate bows. The notation is in treble clef with a key signature of three sharps (F#, C#, G#) and a 4/4 time signature. The scale is written across two staves. The first staff contains the first two octaves, and the second staff contains the third octave. Fingerings are indicated by numbers 1, 2, 3, 4, and 0 (open string). The bowing is indicated by the phrasing of the notes, with separate bows for each note or group of notes.

Scale, slurred bows

Musical notation for the A major scale, three octaves, using slurred bows. The notation is in treble clef with a key signature of three sharps (F#, C#, G#) and a 4/4 time signature. The scale is written across two staves. The first staff contains the first two octaves, and the second staff contains the third octave. Fingerings are indicated by numbers 1, 2, 3, 4, and 0 (open string). The bowing is indicated by slurs over groups of notes, suggesting a single bow stroke for each group.

or

Musical notation for a two-octave exercise in D major, 4/4 time, with separate bows. The piece consists of two staves. The first staff contains four measures: the first measure has notes D4, E4, F#4, G4 with fingerings 1, 0, 0; the second measure has notes A4, B4, C5, D5 with fingerings 2, 1; the third measure has notes E5, F#5, G5, A5 with fingerings 4, 1, 2; the fourth measure has notes B5, C6, D6, E6 with fingerings 1, 2, 1. The second staff contains four measures: the first measure has notes F#5, G5, A5, B5 with fingering 4; the second measure has notes C6, D6, E6, F#6 with fingerings 1, 4; the third measure has notes G6, A6, B6, C7 with fingerings 1, 2, 0; the fourth measure has notes D7, C7, B6, A6 with fingerings 0, 0.

Arpeggio, separate bows

Musical notation for an arpeggio exercise in D major, 9/8 time, with separate bows. The piece consists of one staff with four measures. The first measure has notes D4, E4, F#4, G4 with fingerings 1, 3, 1, 1, 3, 1; the second measure has notes A4, B4, C5, D5 with fingerings 1, 3, 1; the third measure has notes E5, F#5, G5, A5 with fingerings 4, 1, 3; the fourth measure has notes B5, C6, D6, E6 with fingerings 1, 3, 1.

Arpeggio, slurred bows

Musical notation for an arpeggio exercise in D major, 9/8 time, with slurred bows. The piece consists of one staff with four measures. The first measure has notes D4, E4, F#4, G4 with fingerings 1, 3, 1, 1, 3, 1; the second measure has notes A4, B4, C5, D5 with fingerings 1, 3, 1; the third measure has notes E5, F#5, G5, A5 with fingerings 4, 1, 3; the fourth measure has notes B5, C6, D6, E6 with fingerings 1, 1, 3, 1.

5.3 D \flat major, two octaves

Separate bows

Musical notation for a two-octave exercise in D-flat major, 4/4 time, with separate bows. The piece consists of two staves. The first staff contains four measures: the first measure has notes D3, E3, F3, G3 with fingerings 2, 4, 1; the second measure has notes A3, B3, C4, D4 with fingering 4; the third measure has notes E4, F4, G4, A4 with fingering 1; the fourth measure has notes B4, C5, D5, E5 with fingerings 4, 1. The second staff contains four measures: the first measure has notes F4, G4, A4, B4 with fingering 4; the second measure has notes C5, D5, E5, F5 with fingerings 1, 4; the third measure has notes G5, A5, B5, C6 with fingerings 1, 4; the fourth measure has notes D6, C6, B5, A5 with fingerings 2.

or

Two staves of music in D \flat major, 4/4 time. The first staff contains two measures of eighth-note patterns with fingerings 2, 4, 1, 4, 1, 4, 1, 4, 1, 4, 1, 4, 1, 4, 1, 4, 1. The second staff contains two measures of eighth-note patterns with fingerings 1, 4, 1, 4, 1, 4, 1, 4, 2.

Slurred bows

Two staves of music in D \flat major, 4/4 time. The first staff contains two measures of eighth-note patterns with slurs and fingerings 2, 4, 1, 4, 1, 4, 1, 4, 1, 4, 1, 4, 1, 4, 1. The second staff contains two measures of eighth-note patterns with slurs and fingerings 1, 4, 1, 4, 1, 4, 1, 4, 2.

or

Two staves of music in D \flat major, 4/4 time. The first staff contains two measures of eighth-note patterns with slurs and fingerings 2, 4, 1, 4, 1, 4, 1, 4, 1, 4, 1, 4, 1, 4, 1. The second staff contains two measures of eighth-note patterns with slurs and fingerings 1, 4, 1, 4, 1, 4, 1, 4, 2.

Arpeggio, separate bows

One staff of music in D \flat major, 6/8 time. The first measure contains eighth notes with fingerings 2, 4, 2, 1, 3, 1. The second measure contains eighth notes with fingerings 4, 1, 3, 1, 2, 4, 2. The piece ends with a quarter rest.

Arpeggio, slurred bows

One staff of music in D \flat major, 6/8 time. The first measure contains eighth notes with slurs and fingerings 2, 4, 2, 1, 3, 1. The second measure contains eighth notes with slurs and fingerings 4, 1, 3, 1, 2, 4, 2. The piece ends with a quarter rest.

5.4 E_b major, two octaves

Separate bows

Musical notation for the 'Separate bows' exercise. It consists of two staves in E_b major (two flats) and 4/4 time. The first staff contains two measures: the first measure has notes G₂, A₂, B₂, C₃ with fingerings 2, 4, 1, 4; the second measure has notes D₃, E₃, F₃, G₃ with fingerings 1, 4, 1, 4. The second staff contains two measures: the first measure has notes A₂, B₂, C₃, D₃ with fingerings 4, 1, 4, 1; the second measure has notes E₃, F₃, G₃, A₃ with fingerings 1, 4, 1, 4, followed by a whole rest.

or

Alternative musical notation for the 'Separate bows' exercise. It consists of two staves in E_b major (two flats) and 4/4 time. The first staff contains two measures: the first measure has notes G₂, A₂, B₂, C₃ with fingerings 2, 4, 1, 4; the second measure has notes D₃, E₃, F₃, G₃ with fingerings 4, 1, 4, 1. The second staff contains two measures: the first measure has notes A₂, B₂, C₃, D₃ with fingerings 1, 4, 1, 4; the second measure has notes E₃, F₃, G₃, A₃ with fingerings 1, 4, 2, followed by a whole rest.

Slurred bows

Musical notation for the 'Slurred bows' exercise. It consists of two staves in E_b major (two flats) and 4/4 time. The first staff contains two measures: the first measure has notes G₂, A₂, B₂, C₃ with fingerings 2, 4, 1, 4; the second measure has notes D₃, E₃, F₃, G₃ with fingerings 1, 4, 1, 4. The second staff contains two measures: the first measure has notes A₂, B₂, C₃, D₃ with fingerings 4, 1, 4, 1; the second measure has notes E₃, F₃, G₃, A₃ with fingerings 1, 4, 1, 4, followed by a whole rest. Slurs are placed over the notes in each measure.

or

Alternative musical notation for the 'Slurred bows' exercise. It consists of two staves in E_b major (two flats) and 4/4 time. The first staff contains two measures: the first measure has notes G₂, A₂, B₂, C₃ with fingerings 2, 4, 1, 4; the second measure has notes D₃, E₃, F₃, G₃ with fingerings 4, 1, 4, 1. The second staff contains two measures: the first measure has notes A₂, B₂, C₃, D₃ with fingerings 1, 4, 1, 4; the second measure has notes E₃, F₃, G₃, A₃ with fingerings 1, 4, 2, followed by a whole rest. Slurs are placed over the notes in each measure.

Arpeggio, separate bows



Arpeggio, slurred bows

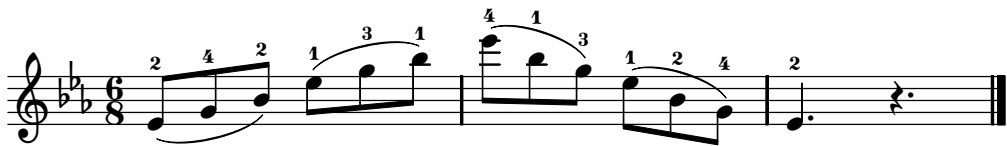

5.5 F major, two octaves

Separate bows

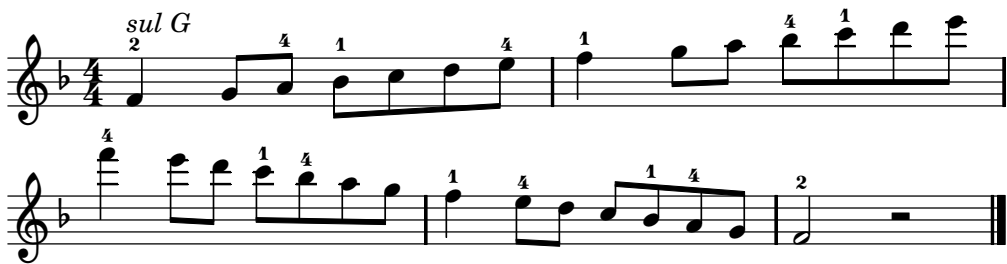

or

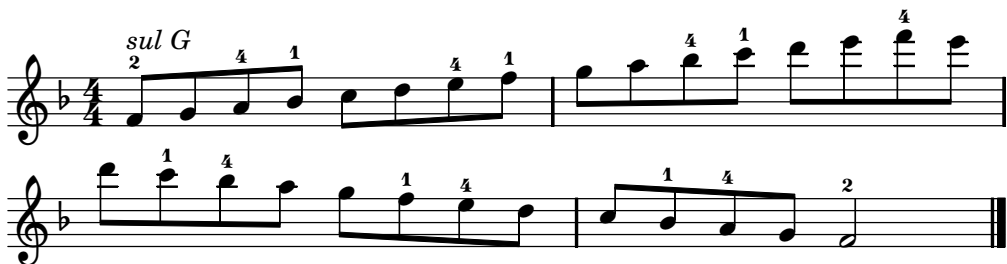

Slurred bows

Musical notation for slurred bows in F major, two octaves, 4/4 time. The piece is in the key of F major (one flat) and 4/4 time. It consists of two staves. The first staff begins with a treble clef, a key signature of one flat, and a 4/4 time signature. The notation includes a *sul G* marking above the first measure. The melody is written in a single line with various slurs and fingerings (1, 2, 4) indicated above the notes. The second staff continues the melody with similar slurs and fingerings, ending with a double bar line.

or

Alternative musical notation for slurred bows in F major, two octaves, 4/4 time. This version also consists of two staves. The first staff begins with a treble clef, a key signature of one flat, and a 4/4 time signature. It includes a *sul G* marking above the first measure. The notation features slurs and fingerings (1, 2, 4) across the notes. The second staff continues the piece with similar slurs and fingerings, concluding with a double bar line.

Arpeggio, separate bows

Musical notation for arpeggio with separate bows in F major, two octaves, 6/8 time. The piece is in the key of F major (one flat) and 6/8 time. It is written on a single staff with a treble clef. The notation includes a *sul G* marking above the first measure. The melody is written in a single line with various slurs and fingerings (1, 2, 3, 4) indicated above the notes. The piece concludes with a double bar line.

Arpeggio, slurred bows

Musical notation for arpeggio with slurred bows in F major, two octaves, 6/8 time. This version is written on a single staff with a treble clef. It includes a *sul G* marking above the first measure. The notation features slurs and fingerings (1, 2, 3, 4) across the notes. The piece concludes with a double bar line.

5.6 G harmonic minor scale, three octaves

Separate bows

Musical notation for the G harmonic minor scale, three octaves, using separate bows. The notation is in 4/4 time and G minor. The first staff shows the ascending scale with fingerings: 0, 0, 0, 2, 1, 4, 1, 2, 1, 4. The second staff shows the descending scale with fingerings: 4, 4, 1, 2, 1, 4, 1, 2, 0, 0, 0.

or

Musical notation for the G harmonic minor scale, three octaves, using separate bows (alternative fingering). The notation is in 4/4 time and G minor. The first staff shows the ascending scale with fingerings: 0, 0, 0, 2, 1, 4, 1, 2, 1, 4. The second staff shows the descending scale with fingerings: 1, 2, 1, 4, 1, 2, 0, 0, 0.

Slurred bows

Musical notation for the G harmonic minor scale, three octaves, using slurred bows. The notation is in 4/4 time and G minor. The first staff shows the ascending scale with slurs over groups of notes and fingerings: 0, 0, 0, 2, 1, 4, 1, 2, 1, 4. The second staff shows the descending scale with slurs over groups of notes and fingerings: 4, 4, 1, 2, 1, 4, 1, 2, 0, 0, 0.

or

5.7 G melodic minor scale, three octaves

Separate bows

or

Slurred bows

Two staves of music in 4/4 time, key of B-flat major. The first staff contains the ascending scale: G2 (0), A2 (0), Bb2, C3, D3, Eb3, F3, G3 (0), A3 (2), Bb3 (1), C4, D4, Eb4, F4, G4 (4), A4 (1), Bb4 (2), C5, D5, Eb5, F5, G5 (4). The second staff contains the descending scale: G5 (4), F5 (4), Eb5 (1), D5 (2), C5 (1), Bb4 (4), Ab4 (1), G4 (2), F4 (0), Eb4 (0), D4 (0), C4, Bb3 (b), Ab3 (b), G3 (0), F3, Eb3, D3, C3, Bb2, Ab2, G2.

or

Two staves of music in 4/4 time, key of B-flat major. The first staff contains the ascending scale: G2 (0), A2 (0), Bb2, C3, D3, Eb3, F3, G3 (0), A3 (2), Bb3 (1), C4, D4, Eb4, F4, G4 (4), A4 (1), Bb4 (2), C5, D5, Eb5, F5, G5 (4). The second staff contains the descending scale: G5 (4), F5 (4), Eb5 (1), D5 (2), C5 (1), Bb4 (4), Ab4 (1), G4 (2), F4 (0), Eb4 (0), D4 (0), C4, Bb3 (b), Ab3 (b), G3 (0), F3, Eb3, D3, C3, Bb2, Ab2, G2.

5.8 A harmonic minor scale, three octaves

Separate bows

Two staves of music in 4/4 time, key of B-flat major. The first staff contains the ascending scale: G2 (1), A2 (0), Bb2, C3, D3, Eb3, F3, G3 (0), A3 (2), Bb3 (1), C4, D4, Eb4, F4, G4 (4), A4 (1), Bb4 (2), C5, D5, Eb5, F5, G5 (4). The second staff contains the descending scale: G5 (4), F5 (4), Eb5 (1), D5 (4), C5 (1), Bb4 (4), Ab4 (1), G4 (2), F4 (0), Eb4 (0), D4 (0), C4, Bb3 (b), Ab3 (b), G3 (0), F3, Eb3, D3, C3, Bb2, Ab2, G2.

or

Two staves of music in 4/4 time. The top staff contains the first two measures of the scale: ascending and descending. The bottom staff contains the next two measures: ascending and descending. Fingerings are indicated by numbers 1, 2, and 0 (open string). The key signature has one sharp (F#).

Slurred bows

Two staves of music in 4/4 time, identical to the previous block but with slurs over the notes to indicate slurred bows. The slurs are placed over the notes in each measure to show the bowing technique.

or

Two staves of music in 4/4 time, identical to the previous block but with slurs over the notes to indicate slurred bows. The slurs are placed over the notes in each measure to show the bowing technique.

5.9 A melodic minor scale, three octaves

Separate bows

Musical notation for the first version of the melodic minor scale, three octaves, using separate bows. The piece is in 4/4 time. The first staff shows the ascending scale with fingerings: 1, 0, 0, 2, 1, #, #, #, #, 1, 2, 1, 2, 1, #, #. The second staff shows the descending scale with fingerings: #, #, #, #, #, #, #, #, 1, 2, 0, 0. The notation includes slurs for each bow stroke and natural/benign accidentals for the descending scale.

or

Musical notation for the second version of the melodic minor scale, three octaves, using separate bows. The piece is in 4/4 time. The first staff shows the ascending scale with fingerings: 1, 0, 0, 2, 1, #, #, #, #, 1, 2, 1, #, #, #. The second staff shows the descending scale with fingerings: #, #, #, #, #, #, #, #, 1, 2, 0, 0. The notation includes slurs for each bow stroke and natural/benign accidentals for the descending scale.

Slurred bows

Musical notation for the first version of the melodic minor scale, three octaves, using slurred bows. The piece is in 4/4 time. The first staff shows the ascending scale with fingerings: 1, 0, 0, 2, 1, #, #, #, #, 1, 2, 1, 2, 1, #, #. The second staff shows the descending scale with fingerings: #, #, #, #, #, #, #, #, 1, 2, 0, 0. The notation includes slurs for each bow stroke and natural/benign accidentals for the descending scale.

or

The image shows a musical score for a three-octave melodic minor scale in 4/4 time, written on two staves. The first staff contains the ascending scale, and the second staff contains the descending scale. The key signature has one sharp (F#), and the scale starts on C4. The ascending scale consists of the notes C, D, E, F#, G, A, B, C, with fingerings 1, 0, 0, 2, 1, 4, 1, 2, 1, 2, 1. The descending scale consists of the notes C, B, A, G, F#, E, D, C, with fingerings 4, 1, 4, 1, 2, 0, 0, 4. The piece concludes with a double bar line.

5.10 B harmonic minor scale, two octaves

Separate bows

or

Slurred bows

or

5.11 B melodic minor scale, two octaves

Separate bows

or

Slurred bows

or

5.12 C# harmonic minor scale, two octaves

Separate bows

Two staves of music in C# harmonic minor scale, two octaves, 4/4 time. The first staff contains the first two measures of the scale, and the second staff contains the next two measures. Fingerings are indicated by numbers 1, 2, and 4 above the notes.

or

Two staves of music in C# harmonic minor scale, two octaves, 4/4 time. This version shows an alternative fingering for the same scale. Fingerings are indicated by numbers 1, 2, and 4 above the notes.

Slurred bows

Two staves of music in C# harmonic minor scale, two octaves, 4/4 time. The notes in each measure are slurred together, indicating a single bow stroke per measure. Fingerings are indicated by numbers 1, 2, and 4 above the notes.

or

Two staves of music in C# harmonic minor scale, two octaves, 4/4 time. This version shows an alternative slurring and fingering for the same scale. Fingerings are indicated by numbers 1, 2, and 4 above the notes.

5.13 C# melodic minor scale, two octaves

Separate bows

or

Slurred bows

or

5.14 E harmonic minor scale, two octaves

Separate bows

or

Slurred bows

or

5.15 E melodic minor scale, two octaves

Separate bows

or

Slurred bows

or

5.16 G minor arpeggio, three octaves

Separate bows

Musical notation for G minor arpeggio, three octaves, separate bows. The notation is in G minor (one flat) and 9/8 time. It consists of four measures. The first measure contains the notes G2, Bb2, D3, F3, Ab3, Bb3. The second measure contains the notes C4, Eb4, G4, Bb4, D5, F5. The third measure contains the notes Ab5, Bb5, G5, Eb5, C5, Bb4. The fourth measure contains the notes G4, Bb4, D5, F5, Ab5, Bb5, G5, Eb5, C5, Bb4, G4. Fingering numbers are placed above the notes: 0 2 0 1 3 1 1 3 1 4 1 3 1 1 3 1 0 2 0.

Slurred bows

Musical notation for G minor arpeggio, three octaves, slurred bows. The notation is in G minor (one flat) and 9/8 time. It consists of four measures. The first measure contains the notes G2, Bb2, D3, F3, Ab3, Bb3. The second measure contains the notes C4, Eb4, G4, Bb4, D5, F5. The third measure contains the notes Ab5, Bb5, G5, Eb5, C5, Bb4. The fourth measure contains the notes G4, Bb4, D5, F5, Ab5, Bb5, G5, Eb5, C5, Bb4, G4. Fingering numbers are placed above the notes: 0 2 0 1 3 1 1 3 1 4 1 3 1 1 3 1 0 2 0. Slurs are placed over the notes in the second and third measures.

5.17 A minor arpeggio, three octaves

Separate bows

Musical notation for A minor arpeggio, three octaves, separate bows. The notation is in A minor (no sharps or flats) and 9/8 time. It consists of four measures. The first measure contains the notes A2, C3, E3, G3, Bb3, C4. The second measure contains the notes D4, F4, A4, Bb4, C5, E5. The third measure contains the notes Bb5, C5, A4, F4, D4, C4. The fourth measure contains the notes A4, C4, E5, G5, Bb5, C5, A4, F4, D4, C4, A4. Fingering numbers are placed above the notes: 1 3 1 1 3 1 1 3 1 4 1 3 1 1 3 1 1 3 1.

Slurred bows

Musical notation for A minor arpeggio, three octaves, slurred bows. The notation is in A minor (no sharps or flats) and 9/8 time. It consists of four measures. The first measure contains the notes A2, C3, E3, G3, Bb3, C4. The second measure contains the notes D4, F4, A4, Bb4, C5, E5. The third measure contains the notes Bb5, C5, A4, F4, D4, C4. The fourth measure contains the notes A4, C4, E5, G5, Bb5, C5, A4, F4, D4, C4, A4. Fingering numbers are placed above the notes: 1 3 1 1 3 1 1 3 1 4 1 3 1 1 3 1 1 3 1. Slurs are placed over the notes in the second and third measures.

5.18 B minor arpeggio, two octaves

Separate bows

Musical notation for the B minor arpeggio, two octaves, using separate bows. The piece is in 6/8 time with a key signature of two sharps (F# and C#). The notation consists of four measures: the first measure contains the first octave (B2, D3, F#3), the second measure contains the second octave (B3, D4, F#4), the third measure contains the first octave (B2, D3, F#3), and the fourth measure contains a whole note B2. Fingerings are indicated by numbers 1-4 above the notes.

Slurred bows

Musical notation for the B minor arpeggio, two octaves, using slurred bows. The notation is identical to the separate bows version, but the notes within each octave are connected by curved lines (slurs) to indicate they are played with a single bow stroke. Fingerings are indicated by numbers 1-4 above the notes.

5.19 C# minor arpeggio, two octaves

Separate bows

Musical notation for the C# minor arpeggio, two octaves, using separate bows. The piece is in 6/8 time with a key signature of three sharps (F#, C#, and G#). The notation consists of four measures: the first measure contains the first octave (C#2, E3, G#3), the second measure contains the second octave (C#3, E4, G#4), the third measure contains the first octave (C#2, E3, G#3), and the fourth measure contains a whole note C#2. Fingerings are indicated by numbers 1-4 above the notes.

Slurred bows

Musical notation for the C# minor arpeggio, two octaves, using slurred bows. The notation is identical to the separate bows version, but the notes within each octave are connected by curved lines (slurs) to indicate they are played with a single bow stroke. Fingerings are indicated by numbers 1-4 above the notes.

5.20 E minor arpeggio, two octaves

Separate bows

Musical notation for the E minor arpeggio, two octaves, using separate bows. The piece is in 6/8 time with a key signature of one sharp (F#). The notation consists of four measures: the first measure contains the first octave (E2, G#2, B2), the second measure contains the second octave (E3, G#3, B3), the third measure contains the first octave (E2, G#2, B2), and the fourth measure contains a whole note E2. Fingerings are indicated by numbers 1-4 above the notes.

Slurred bows

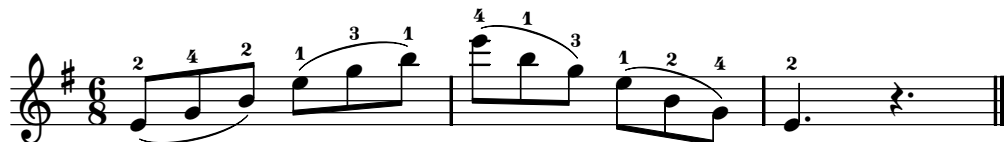

5.21 Dominant 7th in C, two octaves

Separate bows



Slurred bows

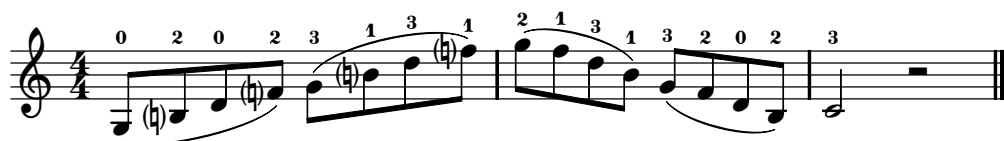

5.22 Dominant 7th in D, two octaves

Separate bows

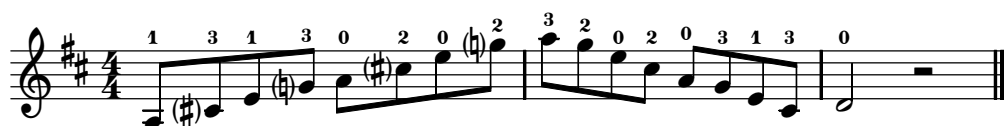

Slurred bows

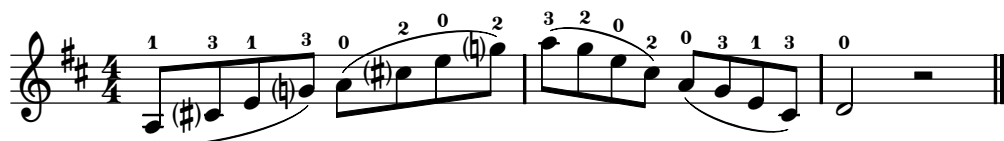

5.23 Dominant 7th in B \flat , one octave

Separate bows



Slurred bows

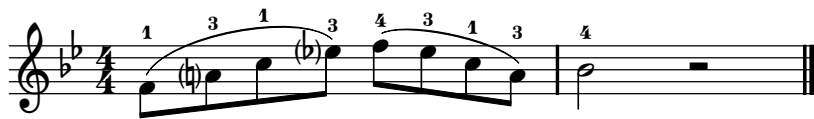

5.24 Diminished 7th starting on G, one octave



5.25 Diminished 7th starting on D, one octave



5.26 Chromatic scale starting on G, two octaves

Separate bows



Slurred bows

Musical notation for a chromatic scale starting on A, two octaves, using slurred bows. The piece is in 4/4 time and consists of three staves. The first staff contains the first two octaves of the scale: A2 (0), B2 (1), C3 (1), D3 (2), E3 (2), F3 (3), G3 (4), A3 (0), B3 (1), C4 (1), D4 (2), E4 (2), F4 (3), G4 (4), A4 (0), B4 (1). The second staff continues the scale: C4 (1), D4 (2), E4 (2), F4 (3), G4 (4), A4 (0), B4 (1), C5 (1), D5 (2), E5 (1), F5 (1), G5 (0), A5 (4), B5 (3), C6 (2), D6 (2). The third staff completes the scale: E6 (1), F6 (1), G6 (0), A6 (4), B6 (3), C7 (2), D7 (2), E7 (1), F7 (1), G7 (0), A7 (4), B7 (3), C8 (2), D8 (2), E8 (1), F8 (1), G8 (0).

5.27 Chromatic scale starting on A, two octaves

Separate bows

Musical notation for a chromatic scale starting on A, two octaves, using separate bows. The piece is in 4/4 time and consists of three staves. The first staff contains the first two octaves of the scale: A2 (1), B2 (2), C3 (2), D3 (3), E3 (4), F3 (0), G3 (1), A3 (1), B3 (2), C4 (2), D4 (3), E4 (4), F4 (0), G4 (1), A4 (1), B4 (2). The second staff continues the scale: C4 (2), D4 (3), E4 (4), F4 (0), G4 (1), A4 (1), B4 (2), C5 (2), D5 (3), E5 (2), F5 (1), G5 (1), A5 (0), B5 (4), C6 (3), D6 (2). The third staff completes the scale: E6 (2), F6 (2), G6 (1), A6 (1), B6 (0), C7 (4), D7 (3), E7 (2), F7 (2), G7 (1), A7 (1), B7 (0), C8 (4), D8 (3), E8 (2), F8 (2), G8 (0).

Slurred bows

Musical notation for a chromatic scale starting on A, two octaves, using slurred bows. The piece is in 4/4 time and consists of three staves. The first staff contains the first two octaves of the scale: A2 (1), B2 (2), C3 (2), D3 (3), E3 (4), F3 (0), G3 (1), A3 (1), B3 (2), C4 (2), D4 (3), E4 (4), F4 (0), G4 (1), A4 (1), B4 (2). The second staff continues the scale: C4 (2), D4 (3), E4 (4), F4 (0), G4 (1), A4 (1), B4 (2), C5 (2), D5 (3), E5 (2), F5 (1), G5 (1), A5 (0), B5 (4), C6 (3), D6 (2). The third staff completes the scale: E6 (2), F6 (2), G6 (1), A6 (1), B6 (0), C7 (4), D7 (3), E7 (2), F7 (2), G7 (1), A7 (1), B7 (0), C8 (4), D8 (3), E8 (2), F8 (2), G8 (0).

5.28 Chromatic scale starting on B \flat , two octaves

Separate bows

Musical notation for 'Separate bows' in 4/4 time, starting on B \flat . The piece consists of three staves. The first staff contains the first two measures of the scale: B \flat (finger 2), B \flat (finger 2), B \flat (finger 3), B \flat (finger 4), B \flat (finger 0), B \flat (finger 1), B \flat (finger 1), B \flat (finger 2). The second staff contains the next two measures: B \flat (finger 2), B \flat (finger 3), B \flat (finger 4), B \flat (finger 0), B \flat (finger 1), B \flat (finger 1), B \flat (finger 2), B \flat (finger 2). The third staff contains the final two measures: B \flat (finger 3), B \flat (finger 2), B \flat (finger 2), B \flat (finger 1), B \flat (finger 1), B \flat (finger 0), B \flat (finger 4), B \flat (finger 3), B \flat (finger 2), B \flat (finger 2). Bowing directions are indicated by 'v' (upbow) and 'v' (downbow) above or below the notes.

Slurred bows

Musical notation for 'Slurred bows' in 4/4 time, starting on B \flat . The piece consists of three staves. The first staff contains the first two measures of the scale: B \flat (finger 2), B \flat (finger 2), B \flat (finger 3), B \flat (finger 4), B \flat (finger 0), B \flat (finger 1), B \flat (finger 1), B \flat (finger 2). The second staff contains the next two measures: B \flat (finger 2), B \flat (finger 3), B \flat (finger 4), B \flat (finger 0), B \flat (finger 1), B \flat (finger 1), B \flat (finger 2), B \flat (finger 2). The third staff contains the final two measures: B \flat (finger 3), B \flat (finger 2), B \flat (finger 2), B \flat (finger 1), B \flat (finger 1), B \flat (finger 0), B \flat (finger 4), B \flat (finger 3), B \flat (finger 2), B \flat (finger 2). Slurs are placed over groups of notes to indicate a single bow stroke.

Violin Scales and Arpeggios, Grades 1-5 by Owain Sutton is licensed under a Creative Commons Attribution-ShareAlike 2.0 UK: England and Wales License.

This document was produced using \LaTeX and Lilypond, running on Arch Linux.